



# Air Rifle Safety & Operation Manual



## WARNING

This airgun is recommended for adult use only. Careless use may result in serious injury or accidental death.

Dangerous within a minimum of 510 yards (470 meters).

Capable of velocity in excess of 1,000 feet per second (305 m.p.s.)

This air rifle should only be used by responsible persons 18 years or older.

Use lead pellets only.

**READ ALL INSTRUCTIONS  
AND WARNINGS BEFORE  
USING THIS AIRGUN.**

**⚠ WARNING:** This air rifle is not a toy and can cause serious injury or death.

**CAUTION:** The airgun should be used only by adults or under adult supervision.

**NOTICE:** Always wear eye and ear protection when using this airgun. This includes people in the immediate vicinity.

**⚠ WARNING:** Always assume the air rifle is loaded. Never leave the airgun loaded if it is not going to be used.

**⚠ WARNING:** Always point the air rifle in a safe direction and be aware of the backstop.

**⚠ WARNING:** Do not point at anything you do not intend to shoot.

**⚠ WARNING:** Do not fire at a target that allows ricochets or deflections. Do not fire into or at water.

**NOTICE:** Be certain that each pellet you use is in the proper caliber for the airgun. Never re-use pellets.

**⚠ WARNING:** Pellets contain lead. Follow all pellet package safety directions. Wash hands thoroughly after handling. Do not put in mouth.

**CAUTION:** Store the airgun (unloaded) and ammunition in separate, safe places, out of reach of children.

**⚠ WARNING:** Do not walk, jump or run when carrying a loaded air rifle. Keep your fingers away from the trigger and do not load the rifle until you are ready to fire.

**CAUTION:** Unload the airgun before putting it in a vehicle.

**NOTICE:** Do not remove from its case or show the air rifle in public.

**NOTICE:** Buyer and user have the duty to obey all laws about the use and ownership of this airgun.

**⚠ WARNING:** Anytime you carry or transport an airgun, make sure the safety is on and the gun is unloaded. Under no circumstances carry or transport when loaded.

**⚠ WARNING:** Do not fill the air cylinder above 206 BAR /3000 PSI. The resulting damage caused by overcharging the bottle is not covered by the manufacturer's warranty.

**⚠ WARNING:** Only use dry-filtered, compressed air or nitrogen to fill the air cylinder. Never use other gases such as oxygen, acetylene, hydrogen, etc.

**NOTICE:** It is recommended that you have the air tank visually inspected every 3 years.

**FAILURE TO OBSERVE THE ABOVE WARNINGS & CAUTIONS CAN RESULT IN DAMAGE TO YOUR AIR RIFLE, ACCIDENTAL DEATH OR SERIOUS INJURY. SAFE SHOOTING IS EVERYONE'S RESPONSIBILITY**

For repairs contact the manufacturer. You will be given instructions how to return the airgun to the factory or other authorized repair station.

AirForce • P.O. Box 2478, Fort Worth, TX 76113  
817-451-8966 • Fax: 817-451-1613 • [staff@airforceairguns.com](mailto:staff@airforceairguns.com)

# Use of Air With the Air Rifle

AirForce air rifles are designed for use with clean, dry compressed air, nitrogen, or carbon dioxide. The maximum fill pressure is 3,000 pounds per square inch (psi), which is 206 bar. A pressure relief device has been installed in the air tank and can rupture if the internal pressure exceeds 3,000 psi/206 bar.

All AirForce airguns have precision rifled barrels. They will shoot accurately only with good quality lead pellets of the appropriate caliber.

**The use of any projectile other than a lead pellet is unauthorized and will void the warranty.**

## Safety First!

Any gun is dangerous when handled improperly, including an airgun. AirForce airguns are especially powerful, so they must be taken seriously at all times. Review the safety rules on the preceding page, plus the special warnings, cautions and notices that appear throughout this manual.

## Airgun Safety

Airguns are unique because the gun provides the power for the shot—not the ammunition. NEVER put anything into the barrel of this airgun except high quality lead pellets.

## Three Important Rules

1. Always point the muzzle in a direction that will not cause injury or property damage if the gun discharges.
2. Keep your finger off the trigger until you are ready to shoot.
3. Don't load the gun until you are ready to shoot.

**NOTICE: READ THIS MANUAL ENTIRELY BEFORE CHARGING OR USING YOUR AIRGUN**

## Specifications

### CondorSS

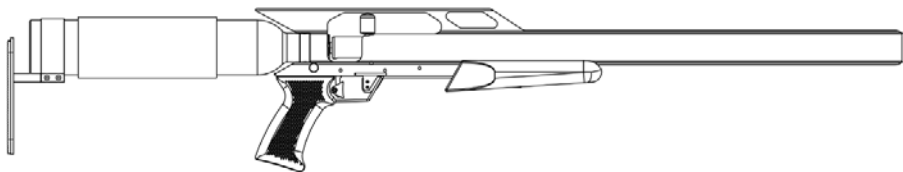

Power Adjustment.....	User adjustable
Max Fill Pressure.....	3000 psi
Action.....	Single shot
Weight.....	6.1 lbs
Length.....	38.75 inches
Barrel.....	18 inches
Caliber.....	0.177, 0.20, 0.22, 0.25
Trigger.....	2 stage, adjustable for position
Safety.....	Automatic on cocking
Air Tank Volume.....	490cc
Velocity.....	600-1300 feet per second
	(Depending on caliber, pellet weight, and power setting)
Sights.....	Open or optical may be installed

### Condor

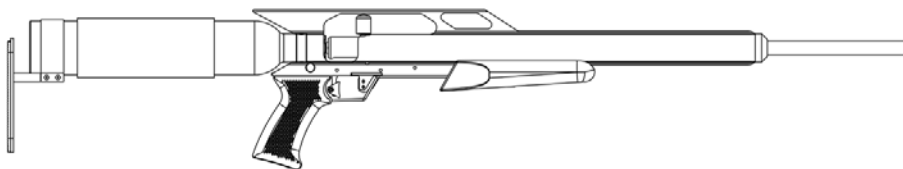

Power Adjustment.....	User adjustable
Max Fill Pressure.....	3000 psi
Action.....	Single shot
Weight.....	6.5 lbs
Length.....	38.125 inches
Barrel.....	24 inches
Caliber.....	0.177, 0.20, 0.22, 0.25
Trigger.....	2 stage, adjustable for position
Safety.....	Automatic on cocking
Air Tank Volume.....	490cc
Velocity.....	600-1300 feet per second
	(Depending on caliber, pellet weight, and power setting)
Sights.....	Open or optical may be installed

*Note: Line drawings above are illustrative of model only and not intended to be accurate for scale or features.*



**WARNING: ALWAYS KEEP THE MUZZLE POINTED IN A SAFE DIRECTION**

## Specifications

### TalonSS

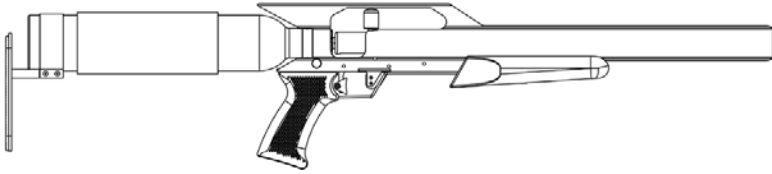

Power Adjustment.....	User adjustable
Max Fill Pressure .....	3000 psi
Action.....	Single shot
Weight .....	5.25 lbs
Length .....	32.75 inches
Barrel.....	12 inches
Caliber.....	0.177, 0.20, 0.22, 0.25
Trigger.....	2 stage, adjustable for position
Safety .....	Automatic on cocking
Air Tank Volume .....	490cc
Velocity .....	400-1000 feet per second
	(Depending on caliber, pellet weight, and power setting)
Sights.....	Open or optical may be installed

### Talon

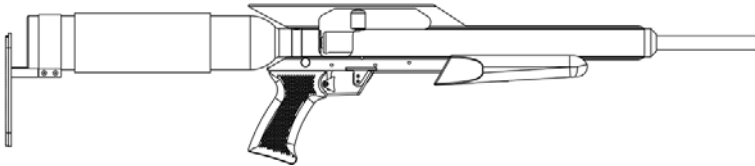

Power Adjustment.....	User adjustable
Max Fill Pressure .....	3000 psi
Action.....	Single shot
Weight .....	5.5 lbs
Length .....	32.6 inches
Barrel.....	18 inches
Caliber.....	0.177, 0.20, 0.22, 0.25
Trigger.....	2 stage, adjustable for position
Safety .....	Automatic on cocking
Air Tank Volume .....	490cc
Velocity .....	400-1000 feet per second
	(Depending on caliber, pellet weight, and power setting)
Sights.....	Open or optical may be installed

*Note: Line drawings above are illustrative of model only and not intended to be accurate for scale or features.*

**NOTICE: READ THIS MANUAL ENTIRELY BEFORE CHARGING OR USING YOUR AIRGUN**

## Nomenclature

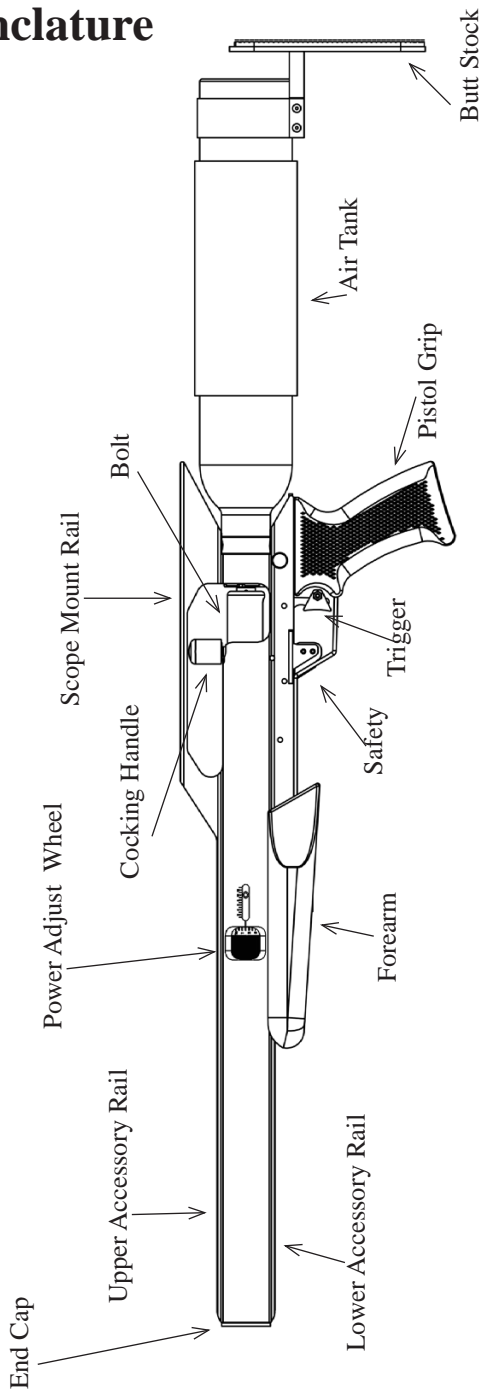



**WARNING: ALWAYS KEEP THE MUZZLE POINTED IN A SAFE DIRECTION**

## **Filling/Attaching the Air Tank** *Standard Quick Detach Tank System*

### **Refill Clamp**

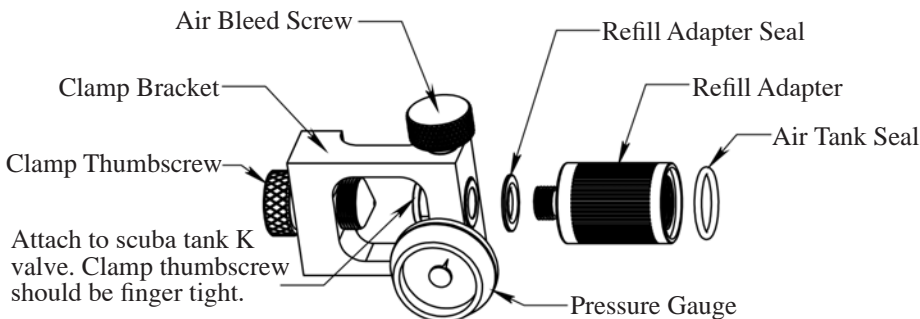

If you fill from a scuba tank that has a K-valve, the AirForce refill clamp is the way to connect your air tank. The square clamp attaches to the K-valve and mates with the O-ring in the scuba tank valve. Once the refill clamp is attached to the scuba tank, close the bleed screw and screw the air tank into the adapter.

### **Filling from a scuba tank**

With the refill clamp attached to the scuba tank and the rifle's air tank attached to the refill clamp, open the scuba tank valve very slowly. Allow at least one minute for the tank to fill, which you can watch on the gauge. Do not exceed 3,000 pounds per square inch/206 bar. When the fill is complete, close the scuba tank valve.

To disconnect the air tank from the refill clamp, open the bleed screw. This allows the high pressure air inside the refill clamp to exhaust, making it possible to unscrew the air tank.

Leave the refill clamp on the scuba tank or put it in a box. Either way, keep the clamp assembly as clean as possible.

### **Attaching the air tank to the rifle**

To install the tank, push forward on the cocking knob lightly to move the bolt out of the tank's way. Screw the air tank into the threaded port at the rear of the rifle frame. The fast-twist threads make tank installation quick and easy, once you have done it a few times.

**NOTICE: READ THIS MANUAL ENTIRELY BEFORE CHARGING OR USING YOUR AIRGUN**

## Filling/Attaching the Air Tank

### *Spin-Loc™ Tank System*

**⚠ WARNING:** Make sure air rifle is unloaded before installing or removing Spin-Loc Sleeve.

**CAUTION:** Frame must be equipped with Spin-Loc system to install Spin-Loc tanks.

Slide the air tank into the rear of the frame. See FIGURE 1.

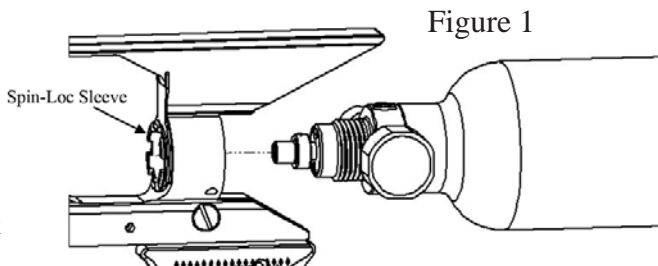

Screw the Spin-Loc Sleeve onto the air tank until it is hand tight. Make sure that the Set Screw is loose and allows the Spin-Loc Sleeve to turn freely. See FIGURE 2.

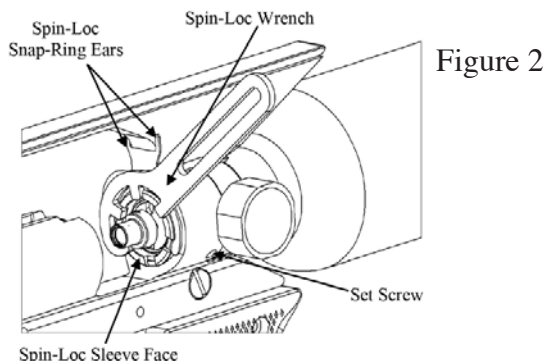

Use the Spin-Loc Wrench to tighten the air tank in place. Use CARE so you will not scratch your aluminum Frame. See FIGURE 2.

**NOTE:** If you have a Quick-Detach Air Tank, without the gauge and refill fitting, tighten the set screw to keep the Spin-Lock Sleeve from turning. Then screw in your Quick-Detach Tank as you normally do in a standard frame.

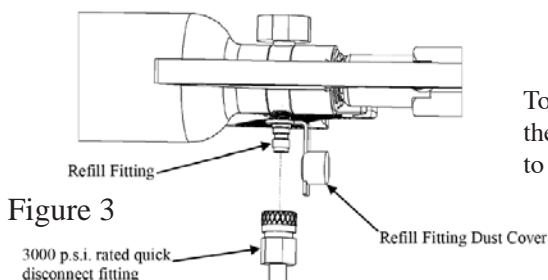

To refill your Spin-Loc Tank, attach the 3000 p.s.i. rated quick disconnect to the refill fitting. See FIGURE 3.





**WARNING: ALWAYS KEEP THE MUZZLE POINTED IN A SAFE DIRECTION**

## Cocking, uncocking, loading, firing

**⚠ WARNING:** Before loading your airgun, make sure the safety is in the On Safe position and the muzzle is pointed in a safe direction.

Manually move the safety to the On Safe position by sliding safety lever back towards trigger.

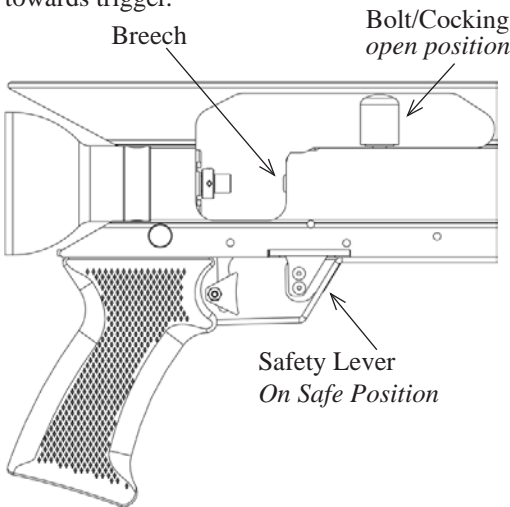

To cock the rifle, push forward on the cocking knob until the bolt is held in the open position.

To load a pellet, cock the rifle and leave the bolt forward, exposing the breech. Push a pellet **ALL THE WAY** into the breech with your thumb or a pellet-seating tool. This is important, because a pellet not pushed in all the way can hold the valve open when the rifle fires, exhausting all the air from the tank.

After loading, slide the bolt all the way back and rotate it into either notch at the rear of the cocking slot. This indicates the bolt is all the way back.

To fire, take aim, slide the safety to the On Fire position and squeeze the trigger until the rifle discharges.

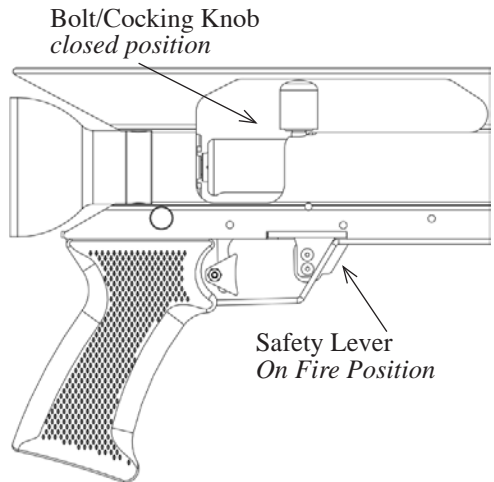

**⚠ WARNING:** Do not move the safety to the On Fire position unless the air gun is pointed in a safe direction. Safe means that if the gun discharged it would not cause injury or property damage. Mechanical safeties are not infallible and do not replace the need for responsible gun handling practices.

# NOTICE: READ THIS MANUAL ENTIRELY BEFORE CHARGING OR USING YOUR AIRGUN

## Adjusting Power

Power can be adjusted with the power adjust wheel. Power does not adjust evenly as the numbers increase and decrease. Rather, there are zones at which the power settles into a velocity range. For the most precise settings, use a chronograph when adjusting power and note what setting gives what velocity with a particular pellet.

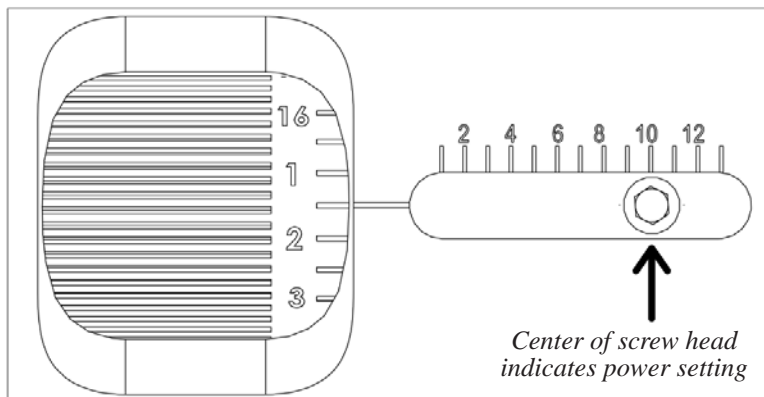

## Talon and Talon SS

Numbers 3 and 4 on the power scale give a good target shooting velocity. Number 6 is a great spot for general shooting. Number 9 or 10 is about as high as the SS will go and still produce many shots. Above 10, air is wasted. Either rifle fitted with an optional 24-inch barrel may be adjusted up as far as the indicator will go.

On the highest power setting, you should get about 35 shots per fill before the velocity begins to drop. On the medium setting, 65 to 75 shots are possible and on the lowest setting well over 200 shots. With a chronograph, you can refine these numbers for your individual rifle.

## Condor and Condor SS

The Condor is made for power. It will shoot heavy pellets as fast as most other air rifles shoot lightweight pellets. When you shoot the heaviest pellets, you can dial the power up all the way and the rifle will be capable of great power with fine accuracy.

You can get about 15 shots at the highest power setting, and up to 20 shots if you are willing to accept a broader velocity range. The thing to do is shoot the rifle at a great distance, perhaps 50 yards or more, and see how many shots will group well before the lowering velocity starts to lower the impact point of the pellet.

The Condor can also be dialed way down in power and still shoot light to medium weight pellets quite fast.



**WARNING: ALWAYS KEEP THE MUZZLE  
POINTED IN A SAFE DIRECTION**

## Operational Tips

### Power adjustments

The rifle needs one shot to settle down following a power adjustment. After that, it should give shots at a consistent velocity.

### Removing or disabling the safety mechanism

Disabling or removing any of the safety parts can disable the rifle and will void the warranty and will create a hazardous condition.

### Modifications to the valve

The valve in the AirForce rifle is not a user-maintainable item. Any attempt to remove or modify the valve in any way will void the warranty and may create a hazardous condition.

### Filling the air tank with a gas other than dry compressed air or nitrogen

This practice is not recommended and voids the warranty for the rifle.

### Cleaning the barrel

An airgun barrel seldom needs cleaning. If you do clean the barrel, use a good quality bore brush of the correct size and use a non-jointed cleaning rod if possible.

Do not use cleaning solvents and agents formulated for firearms because they can damage the seals and O-rings, rendering the rifle inoperative.

### Removing jammed pellets from the barrel

Remove the air tank. Remove the end cap (on SS models) to see the actual muzzle of the barrel. Always attempt to remove jammed pellets from the breech through the muzzle; only go from the muzzle end if there is no other way. Use a good cleaning rod of the correct size to push the jam out of the muzzle.

# NOTICE: READ THIS MANUAL ENTIRELY BEFORE CHARGING OR USING YOUR AIRGUN

## Maintenance of the Air Tank and Care During Shipping

AirForce airguns have an air tank pressurized to 3,000 psi when full. This tank is designed to be filled at all times. You can leave it pressurized to 3,000 psi indefinitely, or you can keep a lower “caretaker” charge of around 2,000 psi in the tank; if you desire.

The air tank is equipped with a safety burst disk that will rupture if the internal pressure gets too high. Under no circumstances should the tank be pressurized beyond 3,000 psi.

To empty the air tank, use the black steel fill adapter that comes with both the AirForce refill clamp and the AirForce pump. It is a separate part and should be separated to perform this operation. Insert one or two dimes in the fill adapter, then screw it on the air tank. As the threads bring the tank and adapter together, the valve will contact the dime(s). Continuing to screw the adapter on the tank will open the valve, exhausting the air inside. Allow this to take as much time as possible, because a rapid exhaust will chill the tank and cause condensation inside. When the tank is completely empty it is safe to ship by any commercial means.

## Safe Shooting

All AirForce airguns are extremely powerful and should always be used with a safe backstop. If you are shooting paper targets, a firearm safe bullet trap is adequate, as long as precautions are taken for safety if the trap is ever missed. We recommend you use a trap that will stop a bullet from a .22 long rifle cartridge fired from a rifle.

Never point the muzzle of the rifle at anything you do not intend to shoot. Make this a habit, so you handle an empty airgun the same way all the time. If you handle all guns this way, you will protect yourself and others if there should be an accidental discharge at some time.

Pellets from all AirForce airguns will explode into dust and fragments when they hit a hard surface like a steel backer plate in a bullet trap. Always wear safety glasses when shooting into a hard bullet trap. If you use a “silent” pellet trap with the rifle, make sure the trap has at least two inches of ballistic putty with a steel backed plate behind it. The rifle should never be shot at a “silent” trap made for airgun use.

In the field, avoid targets that will make the pellet ricochet. These can be both hard targets like plywood, trees and the sides of structures to water, snow, ice or the ground when struck at a shallow angle.



**WARNING: ALWAYS KEEP THE MUZZLE  
POINTED IN A SAFE DIRECTION**

## Troubleshooting

### Gun fails to fire when the trigger is pulled

Is the gun cocked?

Has the safety been taken off?

Is the removable air tank installed?

Is the tank filled with air?

Is anything blocking the valve or the bolt?

Was the bolt closed and rotated to one side before firing?

Is the air tank overfilled, causing valve lock?

### Air is leaking from the tank

Install the air tank on the rifle and fire several times without a pellet. If air continues to leak after this has been tried, it will have to be repaired at the factory.

### Gun fires but pellet remains in the barrel

Is the air tank filled?

Is the barrel free from obstructions?

Was the bolt closed and turned to one side when you fired?

Is the pellet of the correct caliber for the barrel?

Are you sure the pellet did not exit the barrel? Remove the air tank and look through the rear of the barrel to verify that it is still inside.

### Gun fires with widely varying velocity

Are all the pellets the same?

Are the pellets high quality?

Are you using lead pellets? Synthetic pellets deposit residue in the barrel that can cause velocity variation.

Are the pellets the correct caliber?

Is the air tank filled to 3,000 psi? As the tank drops to 2,000 psi, velocity will start to vary more.

Is the barrel dirty?

Are you shooting the gun with the power adjuster below the number 3? At those settings, the velocity will vary more—especially if the air tank is low.

# NOTICE: READ THIS MANUAL ENTIRELY BEFORE CHARGING OR USING YOUR AIRGUN

## Troubleshooting

### When the gun fires, all the air exhausts from the tank

The cause for this is almost always a pellet that was not seated properly into the breech. The skirt is blown against the breech face when high pressure air first hits it and it creates a high pressure air seal that forces the valve to remain open.

### Air leaks from the refill clamp when filling the air tank

Is the refill clamp bleed valve closed?

Is the refill clamp fitted squarely to the O-ring in the scuba tank I-valve?

Is the refill clamp thumbscrew tight?

### The hand pump doesn't seem to fill the air tank

Is the tank screwed tightly to the adapter on the pump?

Are all the adapter seals installed?

Is the brass bleed screw on the pump base closed?

It can be difficult to determine that the hand pump is filling the air tank when the tank is empty. Air tanks are shipped empty to comply with the law. An empty air tank doesn't SEEM to be filling when you pump the pump. Actually it takes about 75 pump strokes before you notice that the needle on the pump's gauge is slightly above zero. Once the tanks starts to register a charge, you will notice that it takes 14 or 15 pump strokes to raise the tank pressure by 100 psi. That's true at all pressure levels.



**WARNING: ALWAYS KEEP THE MUZZLE  
POINTED IN A SAFE DIRECTION**

## AirForce Warranty for Airguns Sold in the United States

Mailing the enclosed warranty card within 60 days of purchase entitles the original buyer to a warranty covering defects in material and workmanship for the life of the airgun. Any AirForce airgun covered by this warranty will be repaired or replaced at the discretion of AirForce, should a defect in material or workmanship be found.

Normal wear parts such as O-rings and seals, are not covered.

Repairs may only be made by the factory or an authorized service station. This lifetime warranty becomes invalid for any gun that is disassembled or modified in any way not specifically authorized by the factory. This lifetime warranty also becomes invalid for any gun that has been damaged by abuse or improper handling.

For shipping instructions for warranty service call 1-877-247-4867. This warranty is not valid for guns used in governmental or commercial applications. A one-year warranty applies in those instances.

**NOTICE: READ THIS MANUAL ENTIRELY BEFORE  
CHARGING OR USING YOUR AIRGUN**



[www.airforceairguns.com](http://www.airforceairguns.com)

877-247-4867 • 817-451-8966 • (fax) 817-451-1613

P.O. Box 2478 • Fort Worth, TX 76113

*Photographs, drawings, descriptions and other information are purely indicative.  
AirForce reserves the right to change, modify or discontinue products or features at any time.*

*Rev. 03/13*