

**THE
STINGRAY
&
XOCET**

**OWNER'S MANUAL
SERIES 2 MODELS**

**READ THIS MANUAL BEFORE
USING YOUR NEW AIRGUN**



THE FAMOUS NAME IN AIRGUNS

WEBLEY & SCOTT LIMITED

**Frankley Industrial Park, Tay Road, Rubery,
Rednal, Birmingham, B45 0PA, England.**

Telephone: 0121 453 1864. Fax: 0121 457 7846.

Guarantee

The Webley Stingray and Xocet are fully guaranteed against faulty workmanship and defective materials for a period of three years from the original date of purchase provided it has not being misused or tampered with in any way. Should you experience problems with your rifle please consult the dealer from whom it was purchased. This guarantee does not affect your statutory rights.

THE LAW

**KNOW THE LAW ON AIRGUNS AND OBEY IT.
ACT RESPONSIBLY, ACT SAFELY, THEN ENJOY
YOUR SHOOTING!**

WARNING!

Serious damage may occur to yourself or your rifle if the barrel is allowed to snap shut under the influence of the mainspring. Please ensure that your finger is well away from the trigger when cocking the rifle.

Removal of the main spring must be carried out by a qualified repairer. Read the instructions carefully before attempting this procedure to avoid injury.

RUNNING-IN

During the running-in period, after the first few hundred rounds, check the tightness of the stock fixing screws, and periodically thereafter. Failure to keep the stock screws tight can result in broken screws. The correct tightening torque is 2lb. ft. (0.28 Kg m). Use WEBLUBE for lubrication of air rifles, as directed in this manual.

**OUR POLICY IS ONE OF CONTINUAL IMPROVEMENT. WE RESERVE
THE RIGHT TO MODIFY THE SPECIFICATIONS OF THESE PRODUCTS
WITHOUT PRIOR NOTICE.**

USE, CARE AND MAINTENANCE OF THE WEBLEY STINGRAY & XOCET AIR RIFLES.

SPECIFICATION.

The Stingray and Xocet are spring operated, single shot, break-action air rifles fitted with precision rifled barrels, primarily suited to waisted lead pellets. The use of steel darts is not recommended.

The rifles are available in .177 (4.5 mm) and .22 (5.5 mm) calibre's.

The rifles share many special design features, which include:

1. An adjustable 2 stage trigger mechanism.
2. Adjustable forend jaws to ensure accurate barrel alignment is maintained.
3. A machine-cut dovetail is provided for the optional fitting of a scope.
4. A mainspring damper which eliminates spring vibration
5. Custom style ambidextrous beech stocks incorporating double cheekpiece and rubber recoil pad.
5. Open sights with micro -click adjustable rearsights are fitted which may be easily removed where an optional telescopic sight is fitted.
6. All Stingray models are fitted with a manual safe
8. Optional silencers are available to fit all models.

	<u>STANDARD</u>	<u>CARBINE</u>
NOMINAL WEIGHTS:		
STINGRAY (open sights fitted)	8.2lbs (3.7kgs)	7.7lbs (3.5kgs)
XOCET (open sights fitted) (3.1kgs)	7.3lbs (3.3kgs)	6.8lbs
OVERALL LENGTHS:		
STINGRAY	44.3ins. (112.5cm)	38.2ins. (97cm)
XOCET	41.1ins. (104.4cm)	35.0ins. (89cm)
RIFLED BARREL LENGTHS - ALL MODELS:		
Standard	17.5 inches (44.5 cm)	
Carbine	11.4 inches (28.9 cm)	

Stingray and Xocet rifles are supplied fully assembled, packed in specially designed protective boxes, and are ready for immediate use once familiarization with the rifle and an appreciation of the basic safety rules has been completed.

THE BASIC SAFETY RULES ARE:

1. Treat every rifle as if it is loaded.
2. Never point a rifle at anyone, or allow anyone to point a rifle at you, even if you know it is not loaded.
3. Always carry a rifle so the direction of the muzzle is under control, even if you stumble.
4. Always be sure of your target and what lies behind it before discharging your rifle.
5. Never leave a loaded rifle unattended.
6. Beware of targets that tend to cause ricochets.

OPERATING INSTRUCTIONS.

1. With the open hand, sharply tap the muzzle end of the barrel down to open the spring lock. Then using the barrel as a lever, cock the rifle as far as it will go; the trigger sear will be heard to engage with a click.
N.B. Keep the forefinger of the supporting hand clear of the trigger whilst cocking the rifle. Also, never allow the barrel to spring back before the sear is engaged nor pull the trigger until the barrel is returned to the closed position.
2. Insert a pellet into the breech of the barrel (fig. 1) and push the pellet with the finger or thumb only until flush with the end. Close the barrel; the spring lock will automatically engage.
Stingray only - If required, engage the safe by pulling it rearwards as far as it will go. The designed travel of the safe is 3/16" (4.8 mm).

Fig. 1

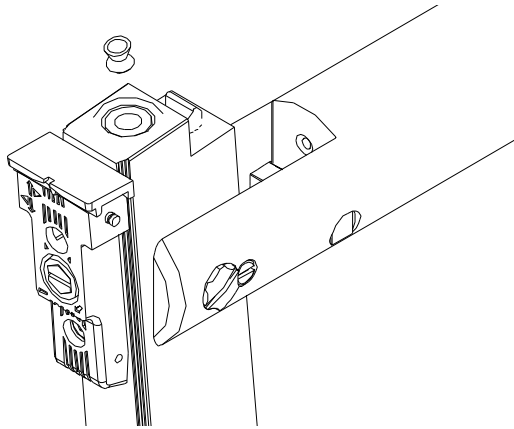

3. When preparing to fire, point the gun towards the target and take a comfortable stance.
Stingray only - If the safe has been applied, push it forward with the right thumb to disengage.
Squeeze the trigger when ready to fire

ROUTINE CARE.

1. Do not fire the rifle without a pellet in the barrel. The only time you have to do this is when adjusting the trigger pull.
 2. Do not leave the rifle cocked or loaded when not in use. Leaving it cocked will reduce the life of the mainspring.
 3. After use, wipe the rifle with an oily rag to prevent corrosion. Use Weblube gun oil.
 4. Occasionally apply three or four drops of Weblube gun oil to:
 - a) Barrel pivot (2648).
 - b) Loading lever axis pin (1266).
 - c) Piston slots and skirt. Access is through the loading lever slots in the stock and body tube assembly.
 - d) Piston seal. Access is through the air feed hole in the breech face.
- IMPORTANT. SERIOUS DAMAGE TO THE PISTON SEAL MAY RESULT IF IT IS EXCESSIVELY LUBRICATED.**
- e) Barrel locking plunger (2989)(fig.2).

Fig. 2 (The stock does not need to be removed to undertake this operation).

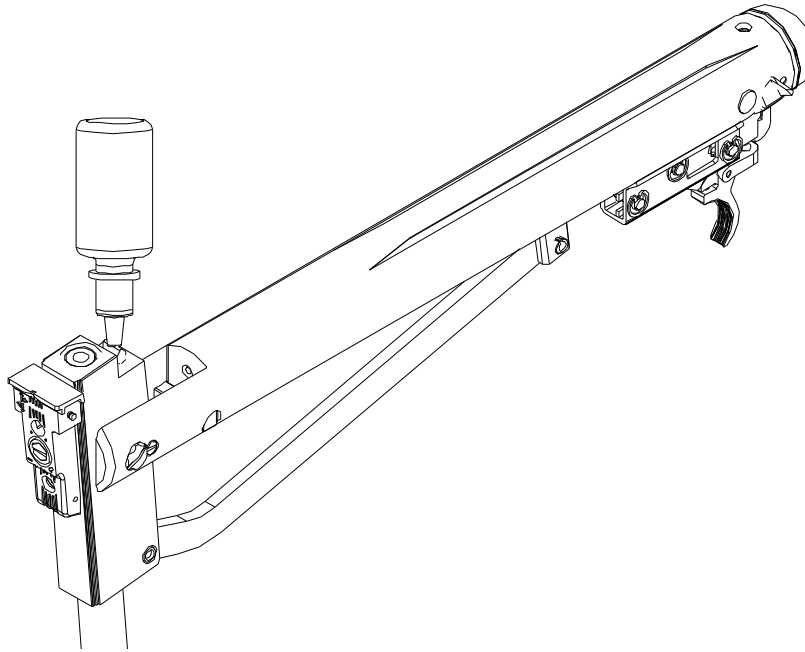

f) Sear and trigger fulcrum pins (2412 & 2100) - very occasionally when stock is removed.

Fig. 3

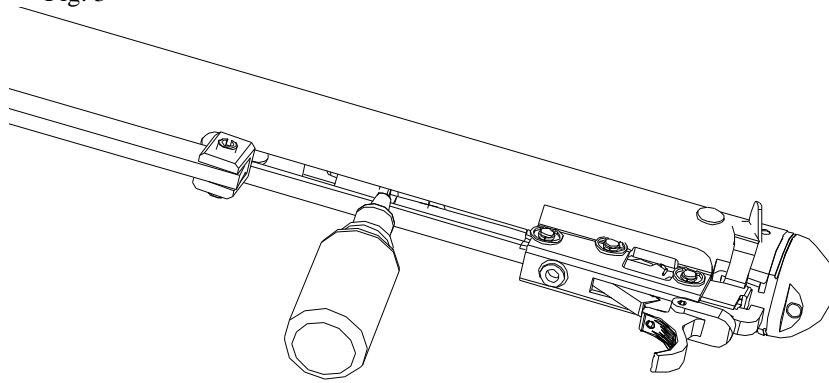

TRIGGER ADJUSTMENT.

There are two means of adjustment to the trigger pull. The first adjustment alters the length of the first stage and is achieved by turning the screw running through the trigger blade (3417). Turning the screw clockwise makes the first stage travel shorter (fig. 4).

Fig. 4

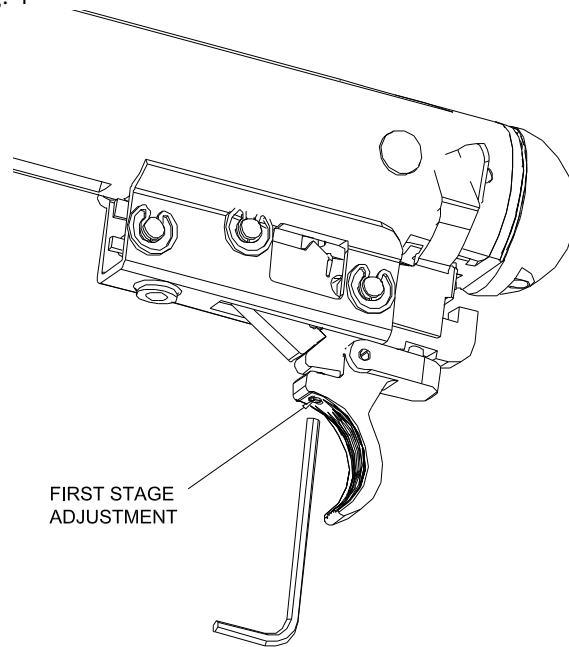

The second adjustment is to the pull weight and is achieved by varying the compression of the trigger spring (2289). The range of adjustment is approximately 3 to 5 lb. (1.36 to 2.27 kg). The adjusting screw is located on top of the body tube, (fig. 5) and is flush at the lowest pull weight setting. The corresponding movement of the screw is 1/4" (6.35 mm).

Using a suitable Allen key, turn clockwise to increase the trigger pull and anti-clockwise to lighten the trigger pull. Do not unscrew above the top of the body end plug, otherwise contact with the spring will be lost. Conversely, do not over-tighten, causing the spring to be compressed solid and thus preventing movement of the trigger.

Always remember to check that the safe is disengaged (Stingray only) when checking the trigger pull and to point the rifle towards the ground, even without a pellet in the barrel.

Fig.5

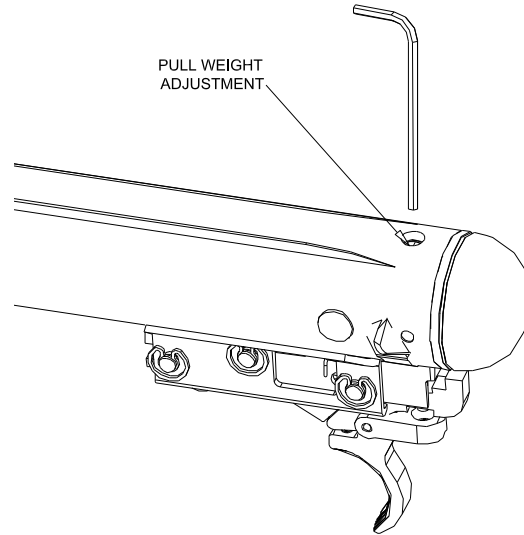

The length of second stage pull cannot be altered.

REMOVING OR FITTING THE OPEN FORESIGHT ASSEMBLY.

STINGRAY

When required, the foresight can be removed or replaced as a complete sub-assembly. The correct tightening torque for the foresight fixing screw (2929) is 2lbs. ft. (0.28 Kg m).

A muzzle blanking screw is provided to seal the tapped hole in the muzzle should the rifle be used with the foresight removed.

XOCET

The foresight assembly is secured by a 2 B.A. socket set screw (2852). Take note that the screw lies at an angle of 30° from the perpendicular when inserting the key. Use a suitable Allen key; the correct tightening torque is 2lbs.ft (0.28 kg m). As a guide to the correct tightening torque, the key will spring through an angle of about 10° to 15°. When refitting or replacing a foresight, make sure that the blade is perfectly perpendicular before tightening the fixing screw, otherwise difficulty will be experienced in re-zeroing the sights.

REMOVING OR FITTING THE OPEN REARSIGHT ASSEMBLY.

STINGRAY

When required, the rearsight can be removed or replaced as a complete sub-assembly (2719). The assembly is secured by two 4 BA caphead screws (1558). Access to the fixing screws and their lockwashers is through the 2 holes in the leaf (2668). Use the correct Allen key provided (fig.6). The correct tightening torque is 2lbs.ft. (0.28 Kg m).

Fig. 6

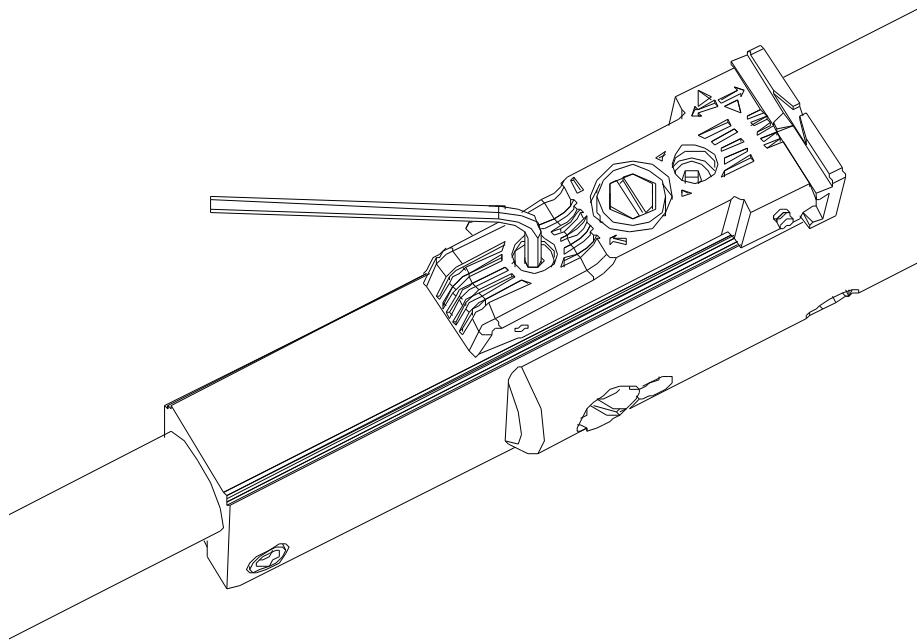

**PARTS LIST FOR THE SERIES 2 WEBLEY STINGRAY AND
SERIES 2 WEBLEY XOCET AIR RIFLES.
REFER TO THE PARTS DIAGRAM OVERLEAF.**

PART No.	DESCRIPTION	No. OFF	PART No.	DESCRIPTION	No. OFF
1266	LOADING LEVER AXIS PIN	1	2823	FORESIGHT - XOCET	1
1277	STOCK FIXING SCREW FRONT	2	2834	MAINSRING DAMPER	1
1279	FULCRUM PIN CIRCLIP	3	2849	REARSIGHT COMPLETE - XOCET	1
1488	TRIGGER ADJUSTING SCREW	1	2850	REARSIGHT VERTICAL ADJUSTMENT NUT - XOCET	1
1558	REARSIGHT BASE FIXING SCREW - STINGRAY	2	2851	REARSIGHT FIXING SCREW - XOCET	1
1559	REARSIGHT BASE FIXING LOCKWASHER - STINGRAY	2	2852	FORESIGHT FIXING SCREW - XOCET	1
1589	REARSIGHT BASE - STINGRAY	1	2854	REARSIGHT VERTICAL ADJUSTMENT STUD - XOCET	1
1599	REARSIGHT LEAF SPRING - STINGRAY	1	2860	MAINSRING .22	1
1603	REARSIGHT LEAF FULCRUM PIN - STINGRAY	1	2869	BARREL LOCKING PLUNGER STOP & COCKING KEY INNER PIN	2
2100	TRIGGER PIVOT ROLL PIN	1	2929	FORESIGHT FIXING SCREW - STINGRAY	1
2224	MUZZLE CAP RETAINING "O" RING - STINGRAY	1	2989	BARREL LOCKING PLUNGER	1
2277	SEAR SPRING - STINGRAY	1	2990	BARREL LOCKING PLUNGER SPRING	1
2289	TRIGGER ADJUSTING SPRING	1	2991	FORESIGHT - STINGRAY	1
2310	FORESIGHT HOOD	1	3144	PISTON SEAL	1
2356	SAFE SLIDE - STINGRAY	1	3323	TRIGGER BLADE	1
2363	MAINSRING .177	1	3324	TRIGGER SEAR	1
2365	BODY END PLUG PIN	1	3338	BODY END PLUG	1
2368	TRIGGER GUARD SCREW REAR	1	3354	BARREL LOCATION PIN	1
2412	FULCRUM PIN	3	3412	MUZZLE TUBE END CAP - STINGRAY	1
2425	SEAR	1	3413	BEECH STOCK - XOCET	1
2541	SEAR SPRING - XOCET	1	3414	BEECH STOCK - STINGRAY	1
2620	TRIGGER GUARD	1	3416	FIRST STAGE TRIGGER SPRING	1
2643	REARSIGHT HOR. ADJ. SCREW - STINGRAY	1	3417	FIRST STAGE ADJUSTMENT SCREW	1
2644	REARSIGHT VERTICAL SCREW INSERT - STINGRAY	1	3428	TRIGGER ASSEMBLY COMPRISING 2100,3323, 3324, 3416,3417 & 3457	1
2645	REARSIGHT VERTICAL SCREW - STINGRAY	1	3457	TRIGGER ADJUSTMENT STOP NYLON	1
2648	BARREL PIVOT SCREW	1	3503	LOADING LEVER	1
2649	BARREL HOUSING SPACER	1	3507	COCKING KEY	1
2655	BARREL PIVOT LOCKING SCREW	1	3553	PISTON	1
2656	BARREL HOUSING DISC WASHER	1	3557	.177 BARREL ASSEMBLY - STINGRAY	1
2657	BREECH SEAL	1	3558	.22 BARREL ASSEMBLY - STINGRAY	1
2668	REARSIGHT LEAF - STINGRAY	1	3559	.25 BARREL ASSEMBLY - STINGRAY	1
2669	REARSIGHT BLADE - STINGRAY	1	3560	.177 CARBINE BARREL ASSEMBLY - STINGRAY	1
2670	REARSIGHT HORIZONTAL CLICK PLUNGER - STINGRAY	1	3561	.22 CARBINE BARREL ASSEMBLY - STINGRAY	1
2671	REARSIGHT HOR. CLICK PLUNGER SPRING - STINGRAY	1	3562	.25 CARBINE BARREL ASSEMBLY - STINGRAY	1
2675	REARSIGHT HOR. ADJ. SCREW CIRCLIP - STINGRAY	1	3563	.177 BARREL ASSEMBLY - XOCET	1
2676	TRIGGER GUARD SCREW FRONT	1	3564	.22 BARREL ASSEMBLY - XOCET	1
2678	WINDAGE SCREW TENSIONING WASHER - STINGRAY	1	3565	.177 CARBINE BARREL ASSEMBLY - XOCET	1
2714	BARREL PIVOT WASHER	1	3566	.22 CARBINE BARREL ASSEMBLY - XOCET	1
2719	REARSIGHT COMPLETE - STINGRAY - COMPRISING 1558 - 2 OFF, 1559 - 2 OFF, 1589, 1599, 1603,2643, 2644, 2645, 2668,2669, 2670, 2671,2675 & 2678	1	3570	LOADING LEVER ASSEMBLY COMPRISING 2816, 2869,3503 & 3507	1
2816	COCKING KEY PIN OUTER	1			

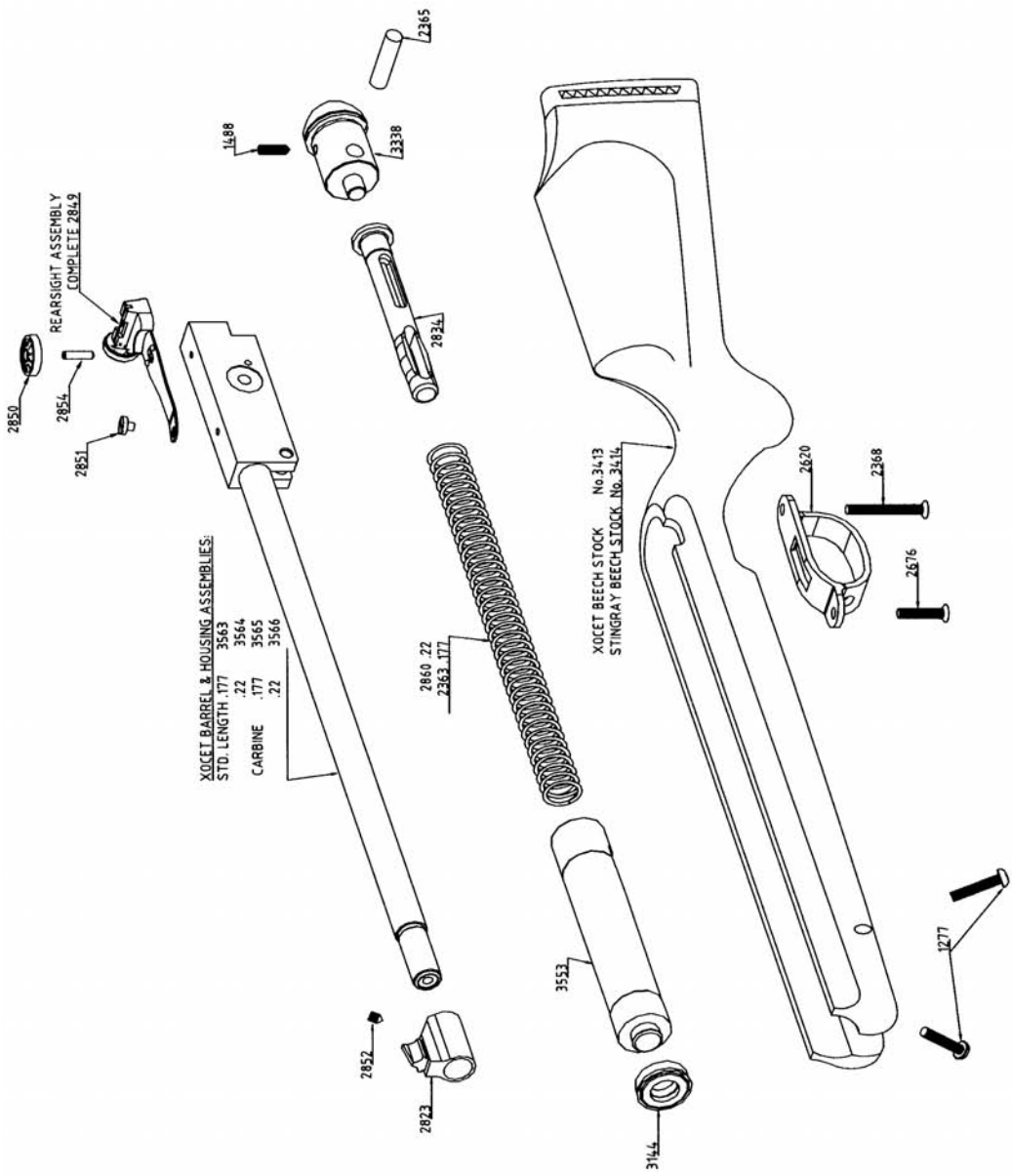

WEBLEY STINGRAY AND XOCET – OLD MODELS

Old model Webley Stingrays and Xocets are fitted with loading levers made from pressings and are not fitted with a cocking key.

Series 2 rifles are fitted with a solid loading lever, part no. 3503.

The following older parts cannot be replaced by Series 2 components. Please ensure you order the correct part for your particular model rifle.

PART No.	DESCRIPTION	No. OFF
1267	LOADING LEVER STOP PIN	1
2366	LOADING LEVER	1
3396	.177 BARREL ASSEMBLY - STINGRAY	1
3418	.22 BARREL ASSEMBLY - STINGRAY	1
3397	.25 BARREL ASSEMBLY - STINGRAY	1
3421	.177 CARBINE BARREL ASSEMBLY - STINGRAY	1
3422	.22 CARBINE BARREL ASSEMBLY - STINGRAY	1
3423	.25 CARBINE BARREL ASSEMBLY - STINGRAY	1
3394	.177 BARREL ASSEMBLY - XOCET	1
3395	.22 BARREL ASSEMBLY - XOCET	1
3419	.177 CARBINE BARREL ASSEMBLY - XOCET	1
3420	.22 CARBINE BARREL ASSEMBLY - XOCET	1

XOCET

When required, the rearsight can be removed or replaced as a complete sub-assembly. To remove, completely unscrew the vertical adjusting nut (2850), then unscrew the 4mm slotted screw (2851). The vertical adjusting stud (2854) is bonded to the barrel housing and should not be removed.

ADJUSTING THE OPEN REARSIGHT (ZEROING).

Although the Stingray and Xocet are fitted with different types of open sights the method of zeroing the rifles is exactly the same.

Always take the same point of aim during adjustment, regardless of the resultant point of impact. Shoot at least five pellets between adjustments, using the average of the group for reference.

Vertical adjustment.

To correct a rifle shooting high, turn the rearsight vertical adjusting screw clockwise to lower the leaf. To correct a rifle shooting low turn the vertical adjusting anti-clockwise to raise the leaf.

Horizontal adjustment.

To correct a gun shooting to the right, turn the rearsight horizontal adjusting screw anti-clockwise to move the blade to the left. To correct a gun shooting to the left, turn the horizontal adjusting screw clockwise to move the blade to the right.

TECHNICAL SERVICE INSTRUCTIONS.

Fitting a new breech seal.

Should the breech seal (2657) become damaged or worn, indicated by loss of velocity and air escaping at the breech, a new one should be fitted. To remove the old one, cock the rifle. Stingray models - apply the safe. Insert a sharp, pointed implement into the annular space occupied by the seal. Pierce the seal and flip it out, taking care not to damage or mark the breech face or the seal recess. (fig. 7)

When fitting a new breech seal ensure that its housing is clean and free of any obstructions. The radiused end of the seal must face outwards so as to lie against the breech face of the action. Ensure that the seal is located in its recess as far as it will go all the way round and that the protrusion above the face is about 0.020" (0.5mm).

Fig.7.

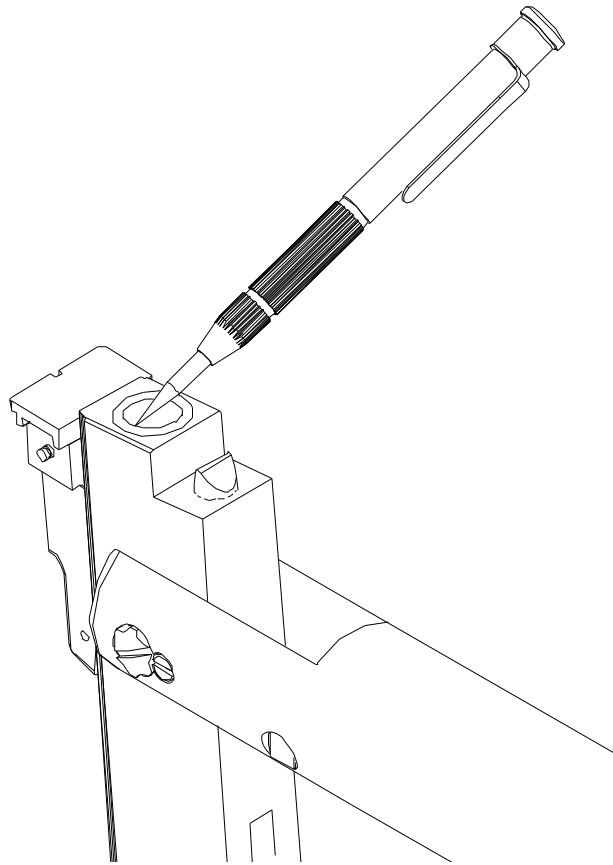

MAJOR OVERHAUL OR REPAIR.
(For a qualified repairer)

Changing the Mainspring and Damper

The need to change the mainspring will become necessary only after the rifle has been fired many thousands of times. The need to change will become indicated by a gradual loss of pellet velocity not attributable to any other cause, e.g. air leaks, mechanical damage, etc.

Removing the old mainspring

First ensure that the rifle is not cocked, then dismantle in the following sequence1.

Detach the stock assembly by removing the two stock fixing screws front (1277), trigger guard screw front (2676), then the trigger guard screw rear (2368).

2. Remove the circlip (1279) from the trigger fulcrum pin (2412), then remove the fulcrum pin and take out trigger assembly (3428). Pull out trigger adjusting spring (2289) located in the underside of the body end plug (3338).
3. Hold the gun upright with the body end plug resting on a table or workbench, press firmly down against the residual spring pressure (this will be about 80lbs. (35kg) on a new gun), then tap out the body end plug pin (2365). Ease the pressure off, allowing the gun to rise against the spring pressure. The end plug complete with mainspring and damper can now be withdrawn.
4. Knock the damper (2834) out of the mainspring. If the mainspring shows signs of buckling, a new one, complete with new damper should be fitted.

Lubricate the mainspring and damper with WEBLUBE, then insert the damper and push firmly home until its flange is flush with the end of the mainspring.

Reassemble in the reverse order.

The preceding paragraphs 1 - 4 relate to the necessary dismantling when replacing the mainspring and damper only. Should it become necessary to dismantle the rifle to carry out a major overhaul or to replace worn components, adopt the procedure stated in the following paragraphs.

Sear/trigger/safe mechanism - Stingray.

Having first removed the trigger and its adjusting spring as described in paragraph 2, remove the two remaining circlips and fulcrum pins, then slide out the safe slide (2356) together with the sear (2425) complete with its spring (2277).

Sear/trigger mechanism - Xocet.

Having first removed the trigger and its adjusting spring as described in paragraph 2, remove the two remaining circlips and fulcrum pins, slide out the sear (2425) complete with its spring (2541).

Barrel Assembly Complete.

To remove the complete barrel assembly, remove the barrel pivot lock screw (2655), then the barrel pivot (2648) and barrel pivot washer (2714). Slide the assembly away from the breech face until the hidden end of the loading lever cocking key (3507) is aligned with the exit hole in the body tube. Pull the end of the cocking key out of the hole (fig. 8). Remove the barrel housing spacer (2649) and disc washer (2656) from their recesses in the barrel housing.

Fig. 8

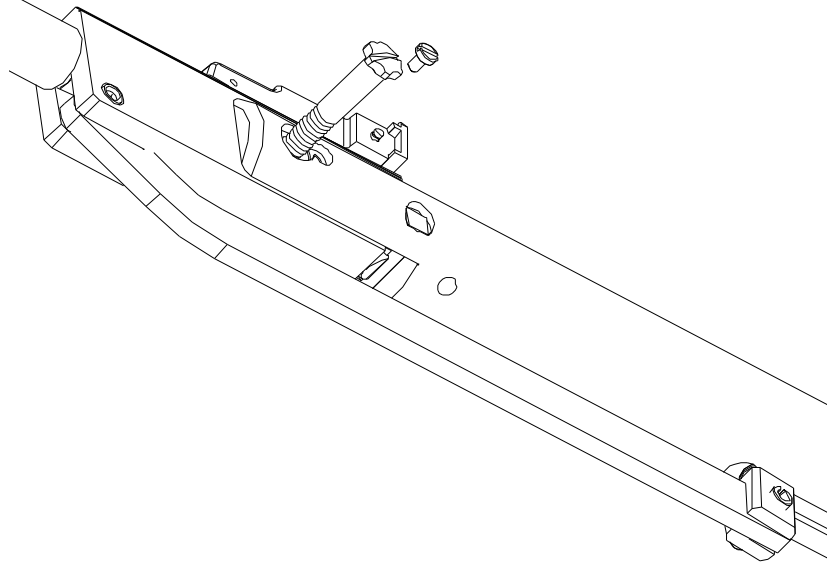

To dismantle the loading lever from the barrel assembly, tap out the loading lever fulcrum pin (1266).

To dismantle the barrel lock mechanism, tap out the barrel locking plunger pin (2869) using a 1/8" (3 mm) diameter drift (fig. 9).

Fig.9

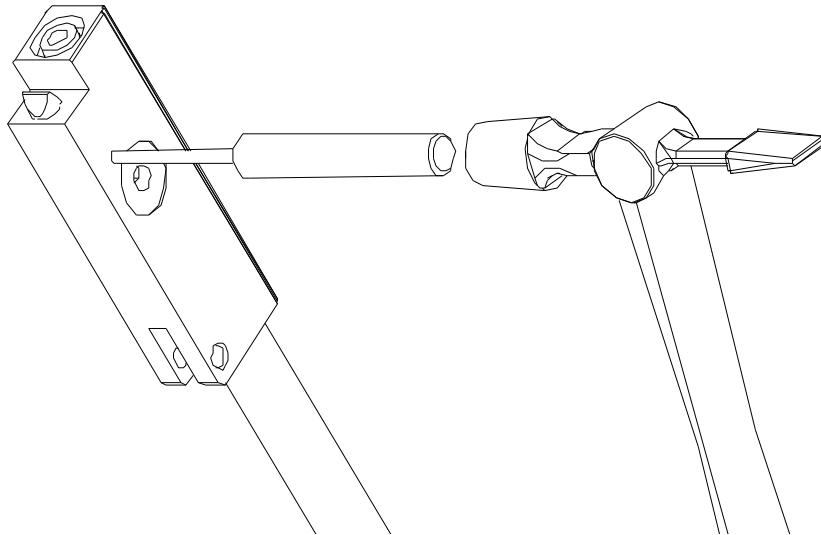

Compress the barrel locking plunger spring (2990) by pushing the barrel locking plunger (2989) and withdraw the drift.

Ease the pressure off the barrel locking plunger allowing the plunger to rise against the spring pressure. The barrel locking plunger, together with the barrel locking plunger spring can now be withdrawn from the barrel housing.

When reassembling the lock mechanism it is advisable to hold the barrel housing in a vice, using soft clamps or cloth to protect its finish.

Assemble the barrel locking plunger pin approx. 1/8" (3 mm) into its hole on one side of the barrel housing - the pin is a drive fit.

Refit the barrel locking plunger spring and barrel locking plunger to the barrel housing. Compress the barrel locking plunger against the spring pressure until its slot straddles the barrel locking plunger pin hole.

Push the 1/8" (3 mm) diameter drift, now used as a slave peg, through the open end of the barrel locking plunger pin hole to retain the barrel locking plunger spring and barrel locking plunger in the barrel assembly.

following paragraphs which cover the remaining components and sub-assemblies.

Drive the barrel locking plunger pin through until it lies centrally within its hole. This operation will push the slave peg out.

Re-assemble the loading lever to the barrel housing, then refit the barrel assembly to the body tube, in the reverse order.

Piston and Seal Assembly.

The piston and seal assembly can only be removed when the mainspring, sear/trigger mechanism and loading lever have dismantled from the body tube.

Insert a small screwdriver through the loading lever slot in the body tube, then carefully push or tap the piston towards the end of the tube taking care not to touch or damage the piston seal (3144). When sufficient piston skirt has emerged, grasp it firmly and pull it right out.

Inspect the piston seal for wear and damage - do not dismantle it from the piston unless renewal is necessary. To remove the old seal, unclip it of the piston location using a screwdriver blade as a lever, alternatively slice through its section with a sharp safety razor blade, penknife or Stanley knife.

Before fitting a new piston seal, first clean, then lubricate the location recess of the piston. Spring the new piston seal over the piston location and push it against the shoulder of the piston, the seal will then automatically into its recess. If necessary, the piston seal may be immersed in boiling water until it becomes sufficiently pliable to clip over the piston (wipe the seal dry before fitting).

Check the seal is located evenly around the piston (fig. 10).

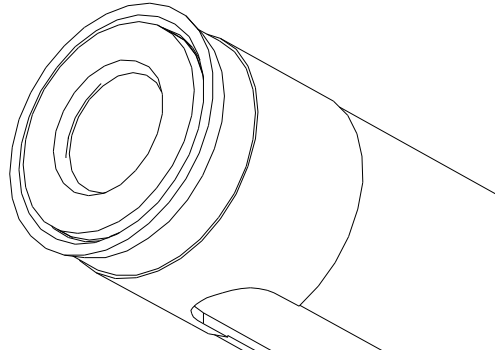

Fig.10

Oil the piston assembly, then wipe the front faces of the seal and piston dry. Clean and lightly lubricate the body tube bore - do not over lubricate.

Refit the piston assembly to the body tube assembly, ensuring their loading lever slots are aligned with one another.

Important Note.

The lip of the piston seal is an interference fit in the body tube. As the piston assembly is pushed down the body tube, take care not to damage the piston seal lip as it passes over body end plug pin holes, safe clearance slot, trigger mechanism slot hidden by the cage and the loading lever slot.

To minimize the risk of damage, deflect inwardly the portion of lip exposed through the holes and slots using a blunt instrument e.g. the blade of a screwdriver (fig. 11).

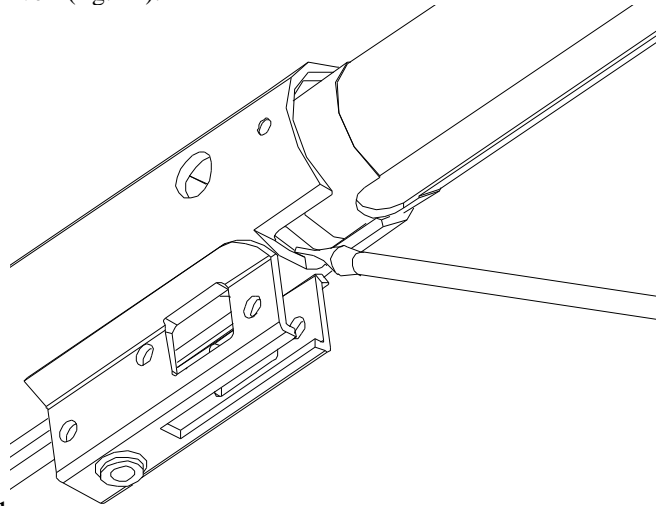

Fig.11

Stingray Rearsight

Should it become necessary to dismantle the blade assembly which provides windage adjustment first remove the circlip (2675), then unscrew the windage screw (2643) until the windage screw detent plunger (2670) becomes visible. Further unscrewing will allow the plunger and its spring (2671) to escape - take care to catch them as they emerge.

Do not forget to replace the rearsight leaf elevating spring (1599) when refitting the rearsight assembly to the action. The correct tightening torque for the fixing screws is 2lbs.ft (0.28 Kg m).

REASSEMBLY.

To avoid difficulties in correctly positioning components, reassemble in the reverse order of dismantling.

During reassembly, the following points should be adhered to, in order to achieve satisfactory performance.

Stingray Sear/Trigger/ Safe Mechanism.

To reassemble the trigger mechanism, place the sear on the safe slide complete with its spring, correctly located, i.e. one end inserted through the small hole in the sear, the other hooked over the safe slide (fig. 12) Feed this sub - assembly into the correct position in the housing, lining up the fulcrum hole in the sear with its mating hole in the housing, then insert the sear fulcrum pin (2412) from the left-hand side until it just locates the sear. The sear fulcrum pin should be pushed in by hand, under no circumstances should any of the trigger mechanism fulcrum pins be knocked or driven in.

Fig.12

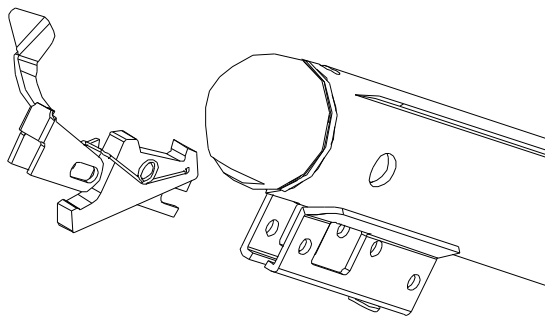

ENSURE AT THIS STAGE THAT THE BODY END PLUG, ETC. IS FITTED BEFORE PROCEEDING WITH REFITTING THE TRIGGER ASSEMBLY

Insert the trigger adjusting spring into its pocket in the underside of the body end plug, then place the trigger in position and fit the remaining fulcrum pin, aligning first the safe then the trigger. Having inserted the pin right through, fit its circlip.

Check that the action functions satisfactorily before re-assembly into the stock.

Xocet Sear/ Trigger Mechanism.

Locate the sear spring onto the RH side of the sear, i.e. its cranked end inserted through the small hole in the sear and its central hole aligned with the sear fulcrum pin hole. Feed this sub - assembly into its correct position in the housing, lining up the fulcrum hole in the sear with its related hole in the housing. Insert the sear fulcrum pin (2412) from the left hand side, push right through then fit its circlip. Insert the front fulcrum pin which acts as a stop for the sear and fit its circlip. It will be necessary to hold the sear against its pressure to avoid blocking the hole when inserting the front fulcrum pin.

ENSURE AT THIS STAGE THAT THE BODY END PLUG, ETC. IS FITTED BEFORE PROCEEDING WITH REFITTING THE TRIGGER ASSEMBLY.

Insert the trigger adjusting spring into its pocket in the underside of the body end plug Then place the trigger assembly in correct alignment in the housing, either pushing or holding the long leg of the sear spring out of the way, towards the body tube. Fit the remaining fulcrum pin and its circlip. Flip the long leg of the sear spring to lie against the fulcrum pin.

Check that the action functions satisfactorily before re-assembly into the stock.