

MODEL
S410
XTRA FAC
5 & 10 SHOT



IF IN GREAT BRITAIN, THE
USER OF THIS MODEL
REQUIRES A FIREARMS
CERTIFICATE

USERS HANDBOOK

THIS HANDBOOK REFERS TO S410E XTRA FAC MODELS

PLEASE READ THIS MANUAL BEFORE USING YOUR NEW RIFLE, IT CONTAINS IMPORTANT SAFETY INFORMATION AND INSTRUCTION ON ADJUSTMENT AND MAINTENANCE.



Illustrated with optional telescopic sight
and mounts.

HIGH POWER MODELS - OVER 20ft/lbs MUZZLE ENERGY

******* SAFETY CODE *******

- 1 - TREAT THIS AIR RIFLE AS IF LOADED.**
- 2 - NEVER POINT IT AT ANYONE, EVEN IF UNLOADED.**
- 3 - NEVER LEAVE THIS RIFLE UNATTENDED WHEN COCKED OR LOADED.**
- 4 - ALWAYS BE SURE OF WHAT LIES BEYOND YOUR TARGET.**
- 5 - ALWAYS CONDUCT YOURSELF IN A SPORTSMAN-LIKE MANNER.**

ALWAYS BE AWARE THAT YOUR ACTIONS WILL BE UNDER THE SCRUTINY OF OTHER MEMBERS OF THE PUBLIC WHO MAY NOT SHARE YOUR ENTHUSIASM FOR AIR WEAPONS. BAD PRACTICES PROMOTE BAD PUBLICITY. DO NOT JEOPARDISE YOUR FUTURE ENJOYMENT BY MISUSING THIS WEAPON.

WARNING! - UNAUTHORISED DISASSEMBLY OF THIS RIFLE WILL INVALIDATE THE MANUFACTURERS WARRANTY

Contents of Box.

- 1 x S410 Rifle.
- 1 x Toll kit consisting of:
 - 1 x 1.5mm allen key
 - 1 x 2.5mm allen key
 - 1 x female filling adaptor.
- 1 x Manual.

Contents	
Important information	Page 3
Barrel cleaning	Page 5
Lubrication	Page 5
Cocking	Page 6
Loading	Page 7
Trigger adjustment	Page 8
Manual safety	Page 9
Power adjuster.	Page 10
Filling instruction	Page 11
Parts list	Page 13

IMPORTANT INFORMATION, PLEASE READ

Before leaving the factory this rifle was Q.A. inspected and test fired using Air Arms PELLETS to check operation and final adjustment.

It was dispatched in a sealed purpose designed box with a contents label on the lid. Air Arms may not be responsible for any damage to the contents or missing items if the box is not original, if it is damaged or the seals are not intact.

Air Arms cannot be held responsible for damage or missing items due to transit damage, mishandling or being tampered with after leaving the factory.

If this rifle is not received in the original box with the seals intact, please examine carefully for any damage, missing tools or documentation.

In the first instance any problems or complaints regarding this product should be referred to the supplier.

The air cylinder is a highly pressurised unit that must **not** be modified in any way. Serious personal injury may result if this, and the advice below is not followed.

Do **not** pressurise the cylinder if there are any surface abrasions or dents. Contact Air Arms for advice.

Do **not** store the rifle in places with, or near sources of high temperature such as fires or boilers.

Do **not** attempt to dismantle when pressurised.

Do **not** pressurise beyond the stated filling pressure (see filling instruction section). Damage caused by such action is **not** covered by the manufacturers warranty.

Only use clean, filtered and dry compressed air. **Never** use any other gas, particularly industrial or welding gases such as oxygen, carbon dioxide, acetylene, hydrogen, argon, etc.

If compressed air is being used other than from a diving shop, the inside of the cylinder should be inspected for corrosion at least annually. If in doubt contact Air Arms for advice.

In any event the cylinder should be inspected every two to three years depending upon usage. Air Arms can provide this service at a reasonable cost.

To maintain this rifle in good working order it should be serviced annually by a competent gunsmith, your supplier may be able to provide this service or contact air arms.

A reasonable amount of advice will be provided to enable the end user to service their own rifle, however this is at the discretion of Air Arms and may not be given in all cases.

The velocity of this rifle has been set using Air Arms field pellets. If any other make or type of pellet is to be used the rifle must be re-tested with the pellet that is to be used, to ensure the muzzle energy is within the limits determined by current legislation.

Due to the nature of hand pumps and their relative inefficiency in removing moisture from the compressed air, the chances of corrosion damage to the cylinder and other internal components are increased. Therefore the rifle should be regularly serviced and/or checked for any signs of damage by a competent gunsmith.

Air Arms recommend using a dry pack filter kit on any hand pumps used to fill our air rifles.

This model is a high power version that requires the user to hold a firearms certificate.

If accessories **not** manufactured by Air Arms are used on this rifle, Air Arms can not be held responsible for any loss of performance.

Contact your supplier or Air Arms for any advice on this matter.

IMPORTANT INFORMATION - Continued

CHECKING VELOCITY

- 1> Use a reliable chronograph to check velocity, (the formula below requires the reading to be in feet per second - FPS)
- 2> Use fine measurement scales to weigh the pellet, If scales are unavailable the pellet weight may be stated on the pellet container lid or contact the supplier. (The formula requires the weight to be in grains). To convert from grams to grains multiply by 15.432, i.e. 0.69 grams x 15.432 = 10.65 grains.
- 3> To find the muzzle energy in ft/lbs use the formula $(FPS \times FPS \times Grains) / 450240$, i.e. $(700 \times 700 \times 10.65) = 5218500$ divide by 450240 = 11.59.

CURRENT LEGISLATION LIMITS NON-FAC HOLDERS TO AIR RIFLES WITH A MAXIMUM OF 12ft/lbs MUZZLE ENERGY.

WARNING! IT IS A VERY SERIOUS OFFENCE TO BE IN POSSESSION OF AN AIR RIFLE THAT YOU ARE NOT CERTIFICATED FOR. CONVICTION CAN RESULT IN CONFISCATION OF YOUR RIFLE, A HEAVY FINE OR IMPRISONMENT, EVEN A COMBINATION OF ALL THREE.

Do **not** store this rifle in a damp place such as garden shed or garage.

Do **not** store this rifle in a plastic or PVC gun bag without first applying a surface corrosion inhibitor.

Always ensure the loading bolt is fully closed before firing.

******* LIMITED LIABILITY WARRANTY *******

This product is warranted to the retail customer for 12 months from date of purchase against defects in materials and workmanship and is transferable to any subsequent owner.

Proof of purchase is required to receive warranty repairs, retain your purchase invoice and return the warranty registration card as soon as possible after purchase. The warranty card must show the dealer/supplier name and address and date of purchase.

What is covered

Replacement parts & labour on a 'back to base' basis, return transportation to the consumer (mainland U.K. only).

What is not covered

Transportation from the consumer to Air Arms.

Damage caused by misuse, abuse, lack of routine maintenance, transit damage between the dealer/supplier and the consumer or unauthorised disassembly.

Parts subject to normal wear and tear.

Any other consequential cost incurred by the consumer.

Return transportation to consumers outside mainland U.K..

No warranty is implied as to the fitness for any particular purpose.

AIR ARMS RESERVE THE RIGHT TO ALTER THE CONSTRUCTION, APPEARANCE OR PERFORMANCE OF ANY PRODUCT WITHOUT PRIOR NOTIFICATION. ALL ILLUSTRATIONS ARE FOR INFORMATION PURPOSES ONLY AND DO NOT NECESSARILY SHOW THE EXACT MODEL THAT WAS PURCHASED.

GENERAL MAINTENANCE AND LUBRICATION

MAINTENANCE

Fixings

Regularly check the tightness of all fixings. However do **not** be tempted to over tighten as some parts are made from aluminium and stripped threads may result. Stripped threads are not covered by the manufacturers warranty.

Barrel

For ultimate accuracy, clean and re-lube the barrel frequently. It is difficult to advise how often is best for every circumstance, but every 250 shots is not too often if the desire is to keep the barrel in the best possible condition.

The correct materials are very important. Air arms only uses products made by napier. Listed below is the napier product and a more generally available alternative. If possible use napier for the best results.

<i>CLEANER :</i>	<i>'NAPIER GUN CLEANER', ALTERNATIVELY WHITE SPIRIT.</i>
<i>OIL :</i>	<i>'NAPIER GUN OIL', ALTERNATIVELY '3 IN 1' OIL.</i>
<i>PULL-THROUGH PAD :</i>	<i>'NAPIER RIFLE CLEAN', ALTERNATIVELY SOFT COTTON CLOTH.</i>
<i>PULL-THROUGH LINE :</i>	<i>20lb FISHING LINE</i>

As a rule cleaners and oils intended for shotguns and small/fullbore weapons are not suitable.

- 1 Cut a piece of line three times the length of your barrel, fold in half and tie ends together. Remove silencer if fitted. Open loading bolt.
- 2 Feed un-knotted end down barrel from the muzzle end until folded end protrudes about 50mm.
- 3 Cut a 100mm length of 'rifle clean' or 100x50mm piece of cloth and pass it between the protruding loop. Spray the pad with 'gun cleaner' or white spirit, turn the rifle upside down and pull the line back through the barrel slowly.
- 4 Repeat steps 2&3 until the pad is clean.
- 5 Repeat steps 2&3 once more without any cleaner on the pad to dry the barrel.
- 6 Repeat steps 2&3 once more with the pad sprayed with 'gun oil' or 3 in 1 oil.

Important : The reason for turning the rifle upside down is to prevent excess cleaner/oil from passing down the transfer port into the firing valve chamber.

Lubrication

Lubrication of the internal mechanism is not covered in this handbook. This is best performed by a competent gunsmith or the factory and in any case should not be required until the annual service.



Apply a small dab of grease on the loading bolt and work-in by moving the bolt forwards and backwards. Wipe off excessive grease. Preferred grease is 'napier g95 gun grease'

On return from every shooting session, wipe all over the exterior with an oily rag to preserve the surface finish during storage.

OPERATING INSTRUCTIONS

COCKING

Hold securely in one hand and with the other turn the loading bolt and pull backwards until the first restriction is felt. Pull back further until the trigger mechanism

Engages. This can be determined by the trigger blade 'kicking' forward at the end of the cocking stroke.

If the bolt is gripped as in the illustration with the thumb on the other side of the bolt knob, the cocking action is much smoother.



Note ! It is very important that the loading bolt is pulled back to the correct position. In one positive motion. The magazine indexes to the next pellet position as the bolt is. Retracted and it is possible for a partial index if the bolt is not pulled back fully.

If you find the mechanism has not cocked completely but the magazine has indexed, Re-cock but before closing the bolt, remove the magazine and manually index it back. To the empty chamber. Replace the magazine and fire as normal. If this procedure is. Not followed it is likely that you will load a second pellet into the barrel.



The rifle is now cocked and loaded, treat with caution.

MOUNTING/DEMOUNTING THE MAGAZINE & PELLETS

DEMOUNTING

Fully cock the rifle, grip the magazine as fig.1 and slide out of the bolt housing without lifting. Do not attempt to lift vertically as damage to the indexing spring will result.

MOUNTING

Fully cock the rifle, grip the magazine as fig.2 and slide in the bolt housing applying downward pressure with the fore finger to keep the base of the magazine against the bottom of the slot in the bolt housing. Take care not to damage the indexing spring.



LOADING PELLETS

Hold the magazine as in fig.3 and drop a pellet into the chamber. Manually index to the next empty chamber as in fig.4 and repeat until the magazine is full. Finally line up the red dot on the pellet carrier with the 'v' notch on the clear magazine cover.

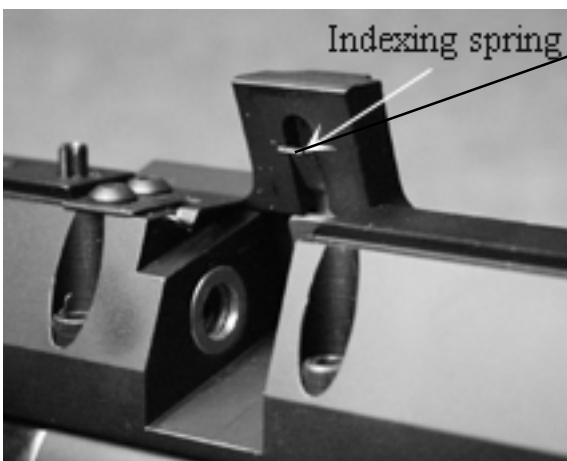

Indexing spring

Be very careful not to damage the Indexing spring when demounting or mounting the magazine. Follow the instructions carefully.

TRIGGER ADJUSTMENTS

The S400 & S410 models all have the same trigger mechanism. It is a two stage unit with adjustment to both stages plus a weight of pull adjustment. It is easy to upset the balance between the two stages and make the trigger inoperable if incorrectly adjusted.

If you have no experience of adjusting two stage triggers seek guidance or leave the trigger as set by the factory.

Note ! Incorrectly adjusted trigger mechanisms are not covered by the manufacturers warranty. It is not possible to test this rifle with an incorrectly adjusted trigger, therefore all triggers leave the factory with correct adjustment.

WARNING ! Please note that it is possible to stop the safety button working with incorrect trigger adjustment.
AN INCORRECTLY ADJUSTED TRIGGER CAN MAKE THE RIFLE UNSAFE TO HANDLE.

DESCRIPTION OF OPERATION

The S400/410 rifles have a true two stage trigger mechanism. This means that as the trigger is pulled the bottom sear gradually disengages with the top sear until the two disengage completely and the rifle goes off. If the pressure on the trigger is released at any point before full disengagement, the bottom sear will automatically return back to full engagement. This type of trigger allows very fine but safe operation because it is the release of the 2nd stage that actually makes the rifle fire. This arrangement is vastly superior to pseudo two stage triggers where the first stage is just a pivoting trigger blade that does not move sears. The down side is that they are more difficult to adjust correctly.

ADJUSTMENT

There are three adjuster screws, a-b-c.

The weight of pull adjuster (a) is located in the front of the trigger guard. Clockwise rotation increases pull weight. If adjusted too far the spring will become coil-bound and prevent trigger operation.

The second stage adjuster (b) is the rear screw located in the trigger blade. This screw determines the exact point that the 2nd stage starts. If the 1st stage screw is incorrectly adjusted this screw may not have any effect.

The first stage adjuster (c) is the front screw located in the trigger blade. This screw determines the length of travel before the 2nd stage starts. Clockwise adjustment reduces the first stage travel.



This rifle is fitted with a manual safety button located in the trigger blade. To make the rifle safe the button must be pressed until it is flush with the side of the trigger blade.

Please note that it is possible to stop the safety button working with incorrect trigger adjustment.

With the button pressed in the rifle is safe.



With the button out the rifle is now ready to fire.

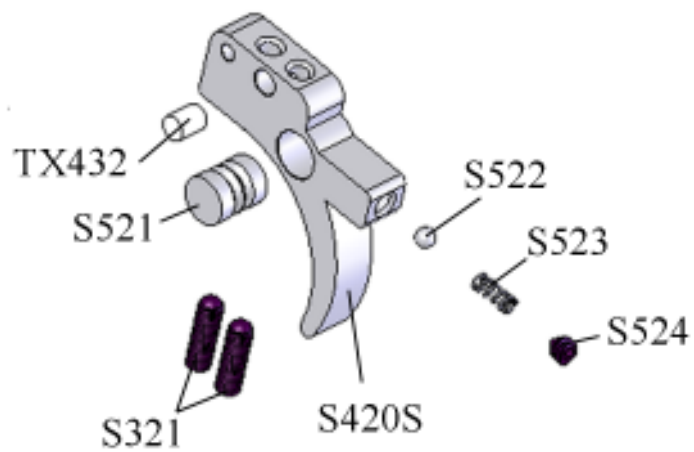

Power Adjuster.

The S410/400 extra is fitted with a power adjuster on the side of the rifle.

This can be used to adjust the power at any time by just turning clockwise to increase and anti-clockwise to decrease the power. Adjusting the power between shots will not harm the rifle.

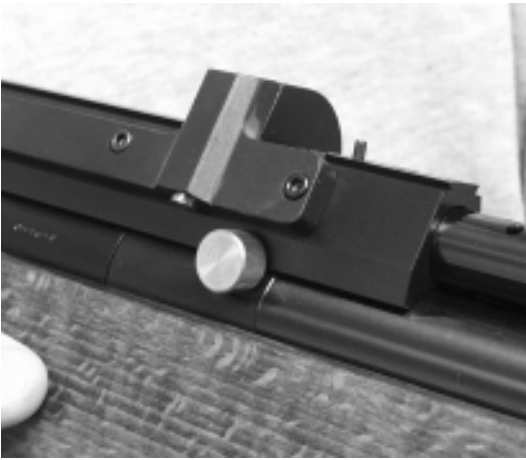

On the left hand side of the rifle is a indicator to help select your most common power settings + = High. - = Low. The marks do not indicate a particular power as this would change depending on the pellets used.



FILLING INSTRUCTIONS

NOTE ! ONLY USE CLEAN, DRY AND FILTERED COMPRESSED AIR, PREFERABLY FROM A DIVING SHOP. OVER PRESSURISATION MAY DAMAGE THE CYLINDER BEYOND REPAIR.

First the female part of the filling kit (this was supplied with the rifle) must be fitted to your filling equipment. The female part (S475) has a 1/8th BSP male thread that screws directly into the hose of your pump or bottle.

Next remove the dust cover from the end of your rifle.



This is achieved by unscrewing the cover in an anti-clockwise direction.

Once the connector is exposed the female part of the filling kit can be placed on the male and press all the way on making sure that the 'O' rings on the male part are covered.

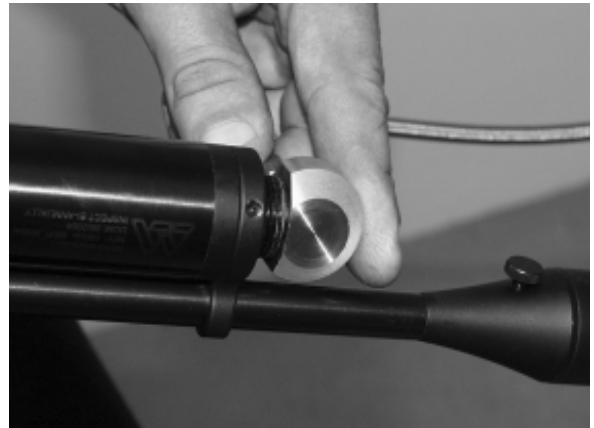

It is a wise precaution to hold the female part of the connector, during the filling procedure, as shown in the pictures below. This will ensure the female adaptor is located completely over the male part and prevent any accidental dislodging of the connector before you start to refill the cylinder.



With the female in place the gun can now be filled.

If the rifle is empty the mechanism will need to be cocked to allow the firing valve to close. If the rifle is not cocked when the bottle is opened or the pump used, the air will past the valve and exhaust through the barrel.

Check that the bleed valve on the filling equipment is closed (turn clockwise to close) then **slowly** open the main valve on bottle or start using the pump. The pressure in the hose will equalise and then the rifle will start to fill.

If you are filling your rifle from empty there may be some air exhausted through the barrel until the air pressure is sufficient to over come the firing valve spring (S306) this will happen at approximately 50 bar (750psi).

The filling pressure of the S400 is 190 bar (2755psi). Filling to a higher pressure will **not** increase either power or number of shots. Over filling will **lower** the power and may cause irreparable damage to the cylinder.

Once the filling pressure has been reached, close the valve on the bottle or stop pumping, open the bleed valve on the filling kit (to vent the hose, if you do not vent the hose you will not be able to remove the female from the rifle). Now the female connector can be removed from the rifle and end cap (S483) can be replaced over the male connector ensuring not to over-tighten.

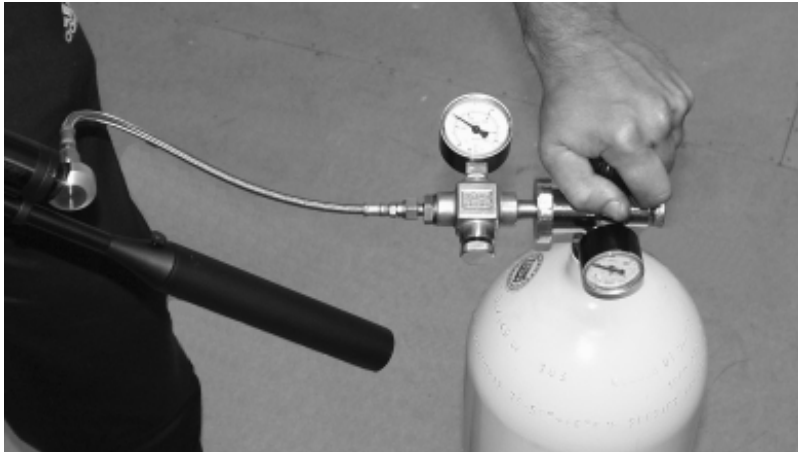

The S400 range of rifles are fitted with a pressure indicator mounted on the underside of the rifle just in front of the stock screw. This provides the user with a visual check on the amount of air remaining in the cylinder this indicator should not be used during the filling process as the needle reaction speed has been slowed to prevent damage whilst filling. After filling the needle can take several seconds to synchronise with the air in the cylinder.



This picture shows a guns with just over 150 bar of pressure.

Although every gun is slightly different the recommended refill pressure for the S400 is between 100 and 110 bar.

NOTE: On the front of the cylinder is an engraved warning reading....

READ MANUAL. MFP200bar. MSP200bar. DOM **//** T45. INSPECT ANNUALLY.**

MFP = Maximum Filling Pressure. The pressure is stated.
MSP = Maximum Safe Pressure. The pressure is stated.
DOM = Date of Manufacture. The date is stated.
T45 = Material used.

WARNING NOTE CONCERNING 300 BAR BOTTLES.

WITH THE ADVENT OF THE 300 BAR BOTTLE IT SHOULD BE NOTED THAT CARE HAS TO BE TAKEN WHEN FILLING YOUR RIFLE.

THE FILLING PROCEDURE DESCRIBED IN THIS MANUAL MUST BE FOLLOWED TO AVOIDED DAMAGE TO THE RIFLE, PARTICULARLY THE SLOW OPENING OF THE VALVE ON THE BOTTLE. OPENING THE VALVE QUICKLY WILL ALLOW UP TO 300 BAR OF PRESSURE INTO THE CYLINDER AT ONCE, THIS COULD CAUSE SERIOUS PERSONAL INJURY OR IRREPARABLE DAMAGE TO THE CYLINDER.

Notes.

PART LIST <> TRIGGER UNIT

PART NO.	DESCRIPTION.	QTY	PART NO.	DESCRIPTION.	QTY
S310	STRIKER BODY	1	S420G	TRIGGER BLADE (GOLD)	1
RN170	TRIGGER STOP PIN	1	S421	TRIGGER ADJUSTMENT SCREW	2
S312	CHASSIS	1	S425	HANDING PIN	1
S315	TRIGGER GUARD	1	S430	CHASSIS COVER PLATE	1
S316	TRIGGER GUARD SCREW (large)	1	S495	TOP SEAR SPRING	1
S319	SPRING	1	S496	TOP SEAR SPRING SCREW	1
S320-2	TOP SEAR	1	S521	SAFETY BUTTON	1
S321-2	BOTTOM SEAR	1	S523	SAFETY BUTTON BALL	1
S322	CHASSIS FIXING SCREW (short)	1	S522	SAFETY BUTTON SPRING	1
S324	TRIGGER CHASSIS COVER SCREW	2	S524	SAFETY BUTTON SCREW	1
S325-2	MIDDLE SEAR	1	TX236	CHASSIS SCREW	1
S326	CHASSIS PIN (small)	3	TX381	TRIGGER WEIGHT OF PULL SCREW	1
S328	CHASSIS PIN SPACER (large)	1	TX398	CHASSIS PIN (large)	1
S329	CHASSIS PIN SPACER (small)	2	TX432	TRIGGER ADJUSTING SCREW LOCKING PAD	1
S420S	TRIGGER BLADE	1	TX460	TRIGGER CHASSIS SCREW	1

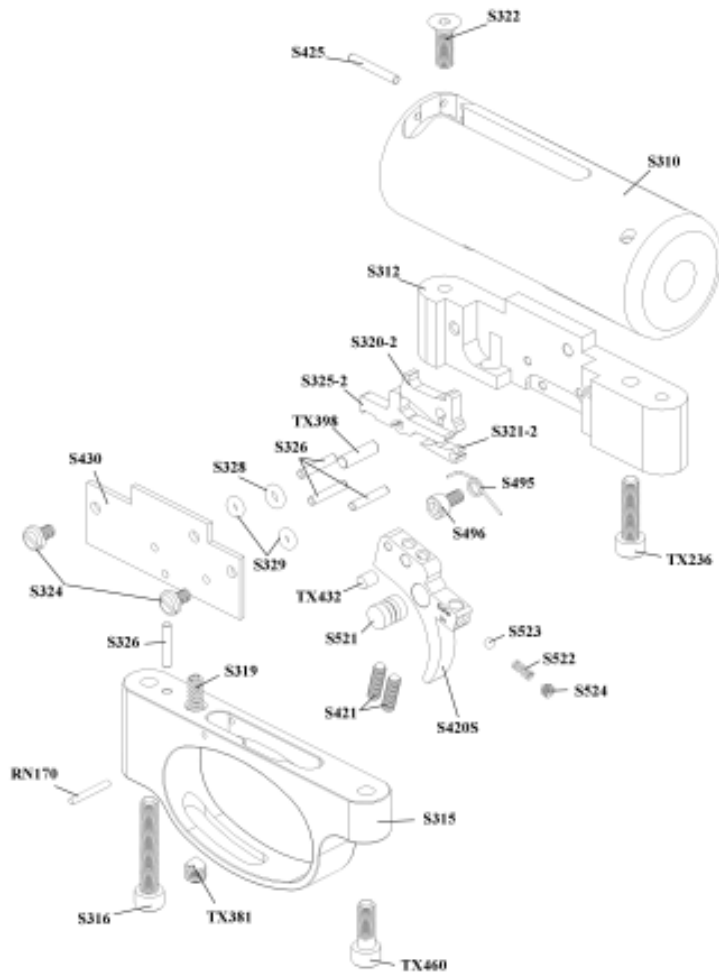

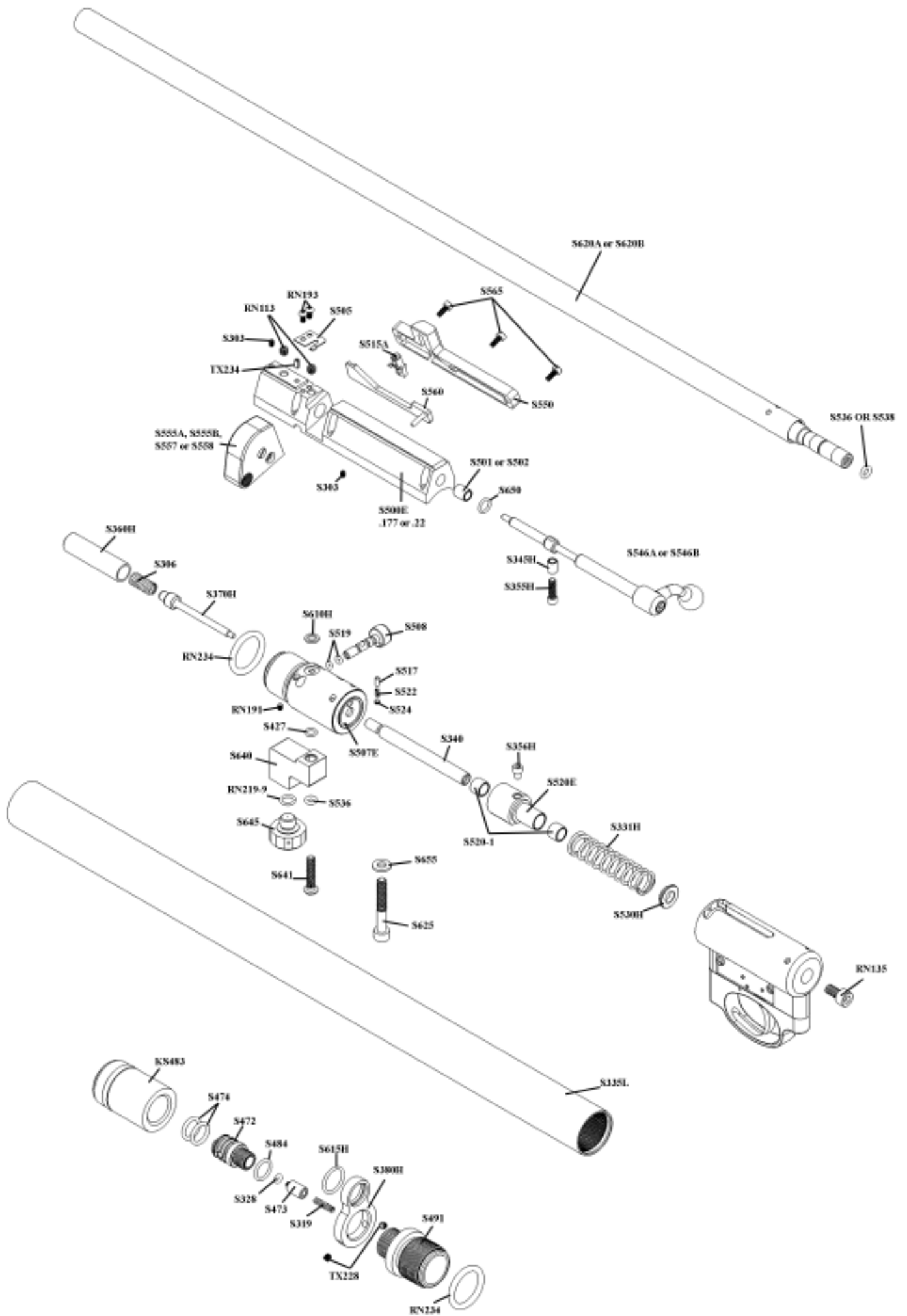

PARTS LIST <> S410-E

PART LIST <> S410 Extra.					
PART NO.	DESCRIPTION.	QTY	PART NO.	DESCRIPTION.	QTY
RN102A	BOLT HSE FIXING SCREW	6	S519	2.5 x 1.5 'O' RING	2
RN113	BARREL FIXING SCREW	2	S520-1	STRIKER BUSH	2
RN135	BODY LOCATION SCREW	1	S520E	STRIKER	1
RN191	POT FIXING SCREW	1	S522	SPRING	1
RN193	MAG RET CLIP SCREW	2	S524	SCREW	1
RN219-9	GAUGE SEAL	1	S530H	SPRING GUIDE	1
RN234	SEALING RING	2	S536	.177 BARREL SEAL & SEALING RING	1
S303	LOCKING SCREW	1	S538	.22 BARREL SEAL	1
S306	FIRING VALVE SPRING	1	S546A	LOADING BOLT ASSEMBLY .177	1
S319	SPRING	1	S546B	LOADING BOLT ASSEMBLY .22	1
S327	VALVE 'O' RING	1	S550	SIDE PLATE	1
S331H	MAIN SPRING	1	S555A	MAG ASSY .177	1
S335L	CYLINDER TUBE	1	S555B	MAG ASSY .22	1
S340	STRIKER GUIDE ROD	1	S557	MAG ASSY .22 5 SHOT	1
S345H	LOADING BOLT SCREW SLEEVE	1	S557	MAG ASSY .22 5 SHOT OPTIONAL	1
S355H	LOADING BOLT SCREW	1	S558	MAG ASSY .177 5 SHOT	1
S356H	STRIKER SCREW	1	S560	CAMPLATE	1
S360H	POT	1	S562	PIN	1
S370H	FIRING VALVE	1	S565	SIDE PLATE SCREW	3
S380	BARREL CLAMP	1	S610H	FIRING VALVE BODY SEAL	1
S427	SEALING RING	1	S615H	BARREL CLAMP RING	1
S472	MALE ADAPTOR	1	S620A	BARREL/TUBE ASSY .177	1
S473	VALVE	1	S620B	BARREL/TUBE ASSY .22	1
S474	12x2 'O' RING	2	S625	STOCK SCREW	1
S475	FEMALE ADAPTOR	1	S630	R/H BEECH STOCK	1
KS483	CYLINDER END CAP	1	S631	L/H BEECH STOCK	1
S484	MALE CON 'O' RING	1	S632	R/H WALNUT STOCK	1
S491	FILLING VALVE BODY	1	S633	L/H WALNUT STOCK	1
S500-2E	BOLT HSE .22	1	S634	R/H THUMBHOLE STOCK	1
S500-7E	BOLT HSE .177	1	S635	L/H THUMBHOLE STOCK	1
S501	BOLT HSE BUSH	1	S640	GAUGE MOUNT	1
S502	BOLT HSE BUSH	1	S641	GUAGE MOUNT SCREW	1
S505	MAG RETAINING CLIP	1	S645	GAUGE	1
S507E	FIRING VALVE BODY	1	S650	LOADING BOLT BUFFER	1
S508	POWER ADJUSTER	1	S655	STOCK WASHER	1
S515A	INDEXING POST ASSY	1	TX228	CYLINDER CLAMP SCREW	2
S517	3/32 x 1/4 DOWEL	1			

PLEASE STATE YOUR RIFLE NUMBER IN ANY CORRESPONDENCE.

Air Arms, Unit 6, Hailsham Industrial Park, Diplocks
Way, Hailsham, East Sussex, England BN27 3JF.

Tel: 01323 845853. Fax: 01323 440573.

Website: www.air-arms.co.uk

Email: general@air-arms.co.uk

Notes