

IZH 60/61 air rifle owner's manual



IZH 61



IZH 60



18370 S. Miles Rd
Warrensville Heights, OH 44128
216-292-2570

Record the serial
number of your airgun.....



Follow the warnings and safety procedures shown here and throughout this manual.

Not a toy. Adult supervision required. This airgun is intended for use by those 18 years of age or older. Misuse or careless use may cause serious injury or death. May be dangerous up to 500 yards.

Do not use this airgun until you have read and understood this owner's manual.

Do not inhale dust from lead pellets or put lead pellets in the mouth. Wash hands after handling lead. Lead pellets contain lead, a chemical known to the State of California to cause cancer and birth defects (or other reproductive harm).

Use the correct pellet size for your airgun. Never reuse pellets. The use of any other kind of ammunition can cause injury to you or damage to your airgun.

Keep your finger off the trigger while cocking your airgun. When you are sure of your target and backstop and the area around the target is clear, you may take your airgun off SAFE and squeeze the trigger to fire. Always keep your airgun on SAFE until you're ready to shoot.

Remember to place your target carefully and THINK about what you will hit if you miss the target.

Do not assume your airgun is unloaded if it fails to fire properly!

Never leave your airgun loaded. Always treat an airgun as if it is loaded, even if you think it is not. Always transport your airgun unloaded and in a hard case.

Never point an airgun at another person or in an unsafe direction.

This airgun does not have a safety. YOU are the ultimate safety for your gun.

You and others with you should always wear safety glasses to protect your eyes.

Do not shoot at hard surfaces or at the surface of water. The pellet may bounce or ricochet and hit someone or something you did not intend to hit.

Always choose your target carefully. It is best to shoot at paper targets attached to a safe backstop or a trap intended to safely stop and/or capture airgun ammunition. Your backstop should be checked for wear before and after use. Replace your backstop if the surface is worn or damaged or if a ricochet occurs.

Do not disassemble, tamper with or attempt to repair or modify your airgun. Doing so may void your warranty and may result in injury. Contact Air Venturi at 216-292-2570 for repair.

In the unlikely event your airgun malfunctions or exhibits reduced performance, DO NOT attempt to fix the problem yourself. Call Air Venturi at 216-292-2570 so we can address any issues or have you return your airgun for repair.

Children are attracted to and can operate guns that can cause severe injuries or death. Prevent child access by always keeping guns locked away and unloaded when not in use. If you keep a loaded gun where a child obtains and improperly uses it, you may be fined or sent to prison.

The IZH 60 and 61 are spring-piston air rifles. The 60 model is a single-shot, and the 61 is a 5-shot repeater. Both guns are cocked with a sidelever.

TRIGGER ADJUSTMENTS

The trigger is adjustable in several ways. The forward screw (A) adjusts trigger travel length, the back screw (B) adjusts trigger-pull weight and the screw in the trigger (C) adjusts trigger position. Never adjust the trigger-pull to less than 32 oz.

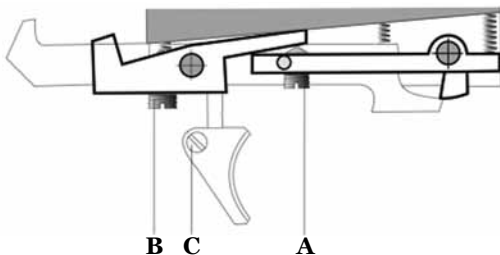

SIGHTS

The sights are made of metal. The front sight is fixed, but the rear is adjustable for windage and elevation.

COCKING & LOADING

Hold the rifle by the forearm with your dominant hand. Keep your fingers off the trigger and away from the breech.

If you have the IZH 60 single-shot rifle: With the barrel pointed in a safe direction, depress the button at the end of the sidelever and pull back the sidelever. You will hear clicking. When the clicking stops, the mainspring is compressed. Never use excessive force when cocking the air rifle. A bolt in the receiver will open the pellet-loading area as you pull back the sidelever. Place a pellet in the loading port and push the bolt closed. Then, push the sidelever back to the starting position. Keep your fingers away from the trigger and breech when moving the sidelever in either direction.

If you have the IZH 61 repeater, insert the loaded magazine from the left side of the rifle (see the **IZH 61 MAGAZINE** section on the next page for additional info). Make sure the “teeth” on one side of the magazine face up. Those teeth will work with the cocking mechanism to move the magazine forward each time you cock the gun. With the barrel pointed in a safe direction, depress the button at the



end of the sidelever and pull back the sidelever. You will hear clicking. When the clicking stops, the mainspring is compressed. Never use excessive force when cocking the air rifle. Push the sidelever back to the starting position. When you cock it the first time, you'll notice that the inserted magazine ratchets forward and aligns the first pellet with the barrel. Each succeeding time you cock, the next pellet will be ratcheted forward to align for the next shot.

Keep your fingers away from the trigger and breech when moving the sidelever in either direction.

IZH 61 MAGAZINE

The IZH 61 is a 5-shot repeater. The magazine has five (5) holes that will accept one (1) .177 -caliber pellet in each hole. Insert the pellets into the magazine and then insert the magazine into the IZH 61, with the nose or head of the pellets facing toward the muzzle (front) of the rifle and the tail of the pellets facing the rear of the rifle. Note in the image above that the magazine has a built-up area on the left side. That is the side that you will hold to insert the loaded magazine into the gun. Since you will insert the magazine from the left side of the gun, that means the pellets you insert in each of the five holes will be inserted in the holes head or nose first.



To remove the magazine, use your right thumb to depress the release button on the top of the receiver and the fingers on your right hand to flip the silver latch on the right side of the receiver. Catch the magazine in your right hand, as it's spring-loaded and will fly out of the loading port.

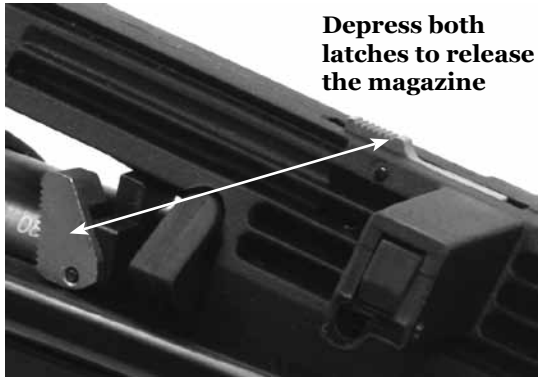

Depress both latches to release the magazine

FIRING

After cocking and loading your rifle, point your airgun in a safe direction and squeeze the trigger. To fire another pellet, follow the previous cocking and loading directions for the type of gun you have.

STOCK

The stock for the IZH 60 and IZH 61 is adjustable. Turn the round knob underneath the buttstock. Once loosened, you can change the length of the buttstock.



Loosen this knob to change the length of the buttstock.

MAINTENANCE

Before doing any maintenance on your airgun, make sure it's unloaded.

Lubricate the air compression chamber with a high-flashpoint oil designed specifically for use inside an air compression chamber. Lubricate the piston seal through the air transfer port, located on the inside bottom of the barrel breech when the magazine has been removed from the IZH 61 or when the bolt has been pulled back on the IZH 60. Oil the airgun (3 to 5 drops) after every 2,000 shots.

Also, lightly oil the cocking arm linkage and bolt pivot points with machine oil every six months.

Do not use firearm cleaners or low-flashpoint oils in the air compression chamber or near the transfer port and breech seal to avoid damaging your airgun.

To lubricate the mainspring, remove the stock. Turn over the action and apply 6 to 10 drops of a light oil onto the spring. Reattach the stock. Oil your gun every 2,000 to 3,000 shots or every six (6) months. Don't use too much oil. Using too little is better than too much.

**If you feel additional maintenance is required,
contact Air Venturi at 216-292-2570.**

Exploded parts view of the IZH 61

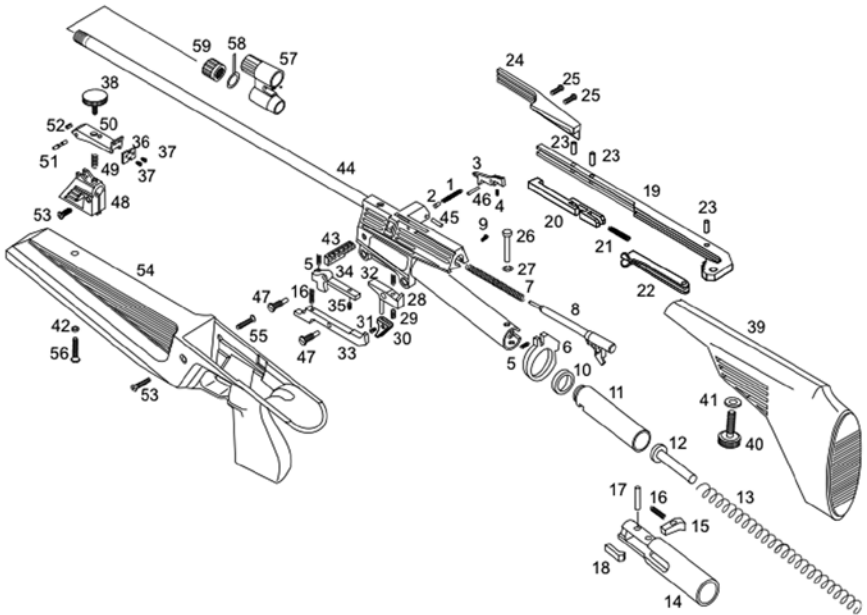

- | | | |
|-------------------------|-------------------------------------|---------------------------------|
| 1. magazine spring | 21. latch spring | 41. buttstock washer |
| 2. plunger | 22. rocker | 42. rim |
| 3. magazine catch | 23. pin | 43. magazine |
| 4. catch spring | 24. cocking lever grip | 44. barrel & receiver assembled |
| 5. spring | 25. cocking grip screw | 45. pin |
| 6. blocking ring | 26. cocking lever pivot | 46. magazine catch pivot |
| 7. follower ring | 27. collar | 47. threaded pivot |
| 8. follower | 28. trigger base | 48. rear sight base |
| 9. screw | 29. trigger-pull adjusting screw | 49. rear sight spring |
| 10. piston seal | 30. trigger | 50. rear sight lever |
| 11. piston | 31. trigger screw | 51. rear sight pivot |
| 12. mainspring guide | 32. trigger spring | 52. rear sight stop |
| 13. mainspring | 33. sear 2 | 53. woodscrew |
| 14. cocking lever base | 34. sear 1 | 54. forend |
| 15. cocking lever catch | 35. trigger travel adjusting screw | 55. woodscrew |
| 16. spring | 36. rear sight leaf | 56. woodscrew |
| 17. catch pivot | 37. sight leaf screw | 57. front sight base |
| 18. catch bar | 38. sight elevation adjusting screw | 58. front sight |
| 19. cocking lever | 39. buttstock | 59. front sight nut |
| 20. cocking lever latch | 40. buttstock screw | |

Warranty registration

Your IZH airgun is manufactured to the highest standards, using the finest materials to give a lifetime of service. In the unlikely event there are any defects in materials or workmanship in the first twelve (12) months after retail purchase, we will repair or replace your airgun under warranty. Keep your original purchase receipt.

What is covered: Replacement parts and labor. Transportation charges to consumer for return of repaired product.

The warranty will be invalid if:

- The airgun has been disassembled and incorrectly reassembled.
- The airgun is found to have lubrication not recommended by Air Venturi.
- The airgun has been fitted with non-Air Venturi parts.
- The airgun has been misused or abused.
- The warranty card was not returned within 28 days of retail purchase and/or the original purchase receipt cannot be presented.

The warranty does NOT cover:

- O-rings, screws, seals, springs or stocks.
- Any damages or faults caused by owner misuse or action.
- Shipment damage of the airgun to or from Air Venturi.
- Transportation charges to Air Venturi for defective products.
- Damages caused by abuse or failure to perform normal maintenance.
- Parts subject to normal wear and tear.
- Consequential damages, incidental damages or incidental expenses including damage to property.
- Any other expense.

Note: Some states do not allow the exclusion or limitation of incidental or consequential damages, so the above limitation or exclusion may not apply to you.

This warranty is in addition to your statutory rights. To register your warranty, the card below must be completed and returned to Air Venturi within 30 days of purchase. Retain your sales receipt as proof of purchase.

Warranty claims: Warranty claims for U.S. and Canadian Customers: Warranty card must be completed and mailed to Air Venturi within 28 days of purchase. Call Air Venturi at 216-292-2570 before returning any product.

Implied warranties: Any implied warranties, including the implied warranties of merchantability and fitness for a particular purpose, are limited in duration to one year from date of retail purchase.

Note: Some states do not allow limitations on how long an implied warranty lasts, so the above limitation may not apply to you.

To the extent any provision of this warranty is prohibited by federal, state or municipal law which cannot be preempted, it shall not be applicable. This warranty gives you specific legal rights, and you may also have other rights which vary from state to state and country to country.

Complete this warranty card and mail to Air Venturi, 18370 S. Miles Rd., Warrensville Hgts., OH 44128.

Serial number:.....Date of purchase:.....

Caliber:.....Where purchased:.....

Your name:

Your address:.....

Your phone:

BASIC SAFETY RULES

1. Never point your airgun at anyone or allow anyone to point an airgun at you, even if you know it is not loaded.
2. Treat your airgun as if it's loaded, even if you know it's unloaded.
3. Aim your airgun in a safe direction.
4. Keep point the muzzle of your airgun pointed in a safe direction.
5. Carry your airgun so the direction of the muzzle is under control, even if you stumble.
6. Keep your airgun unloaded until you are ready to shoot.
7. Check your airgun to make sure it's unloaded when you get it from another person or from storage.
8. Keep your finger off the trigger unless you are ready to shoot..
9. Everyone in the vicinity should wear safety glasses when an airgun is being used, shot or loaded.
10. You and others with you should always wear safety glasses to protect your eyes. If your reading or prescription glasses are not safety glasses, wear safety glasses over your other glasses.
11. This airgun does not have a safety. YOU are the ultimate safety for your gun.
12. Use .177-caliber (4.5 mm) pellets only.
13. Never reuse ammunition.
14. Never leave a loaded airgun unattended.
15. Do not shoot at hard surfaces or at the surface of water. The pellet may bounce off or ricochet and hit someone or something you had not intended to hit.
16. Place the backstop in a location that will be safe should the backstop fail.
17. Be sure of your target and what lies behind it before firing your airgun. Know what you will hit if you miss your target.
18. Your backstop should be checked for wear before and after each use. All backstops are subject to wear and will eventually fail. Replace your backstop if the surface is worn or damaged or if a ricochet occurs.
19. Do not attempt to disassemble or tamper with your airgun. Use an authorized repair center. Using unauthorized repair centers or modifying the function of your airgun in any way may be unsafe and will void your warranty.
20. Before you store your airgun, make sure that it is unloaded.

*Illustrations and photographs are for information purposes only
and may not show the exact model purchased.*



18370 S. Miles Rd
Warrensville Heights, OH 44128
216-292-2570