

S410



TDR

USERS HANDBOOK

THIS HANDBOOK REFERS KS410 MODELS

PLEASE READ THIS MANUAL BEFORE USING YOUR NEW RIFLE, IT CONTAINS IMPORTANT SAFETY INFORMATION AND INSTRUCTION ON ADJUSTMENT AND MAINTENANCE.



TDR SHOWING OPTIONAL SCOPE, MOUNTS AND SPARE MAGAZINES.

******* SAFETY CODE *******

- 1 - TREAT THIS AIR RIFLE AS IF LOADED.**
- 2 - NEVER POINT IT AT ANYONE, EVEN IF UNLOADED.**
- 3 - NEVER LEAVE THIS RIFLE UNATTENDED WHEN COCKED OR LOADED.**
- 4 - ALWAYS BE SURE OF WHAT LIES BEYOND YOUR TARGET.**
- 5 - ALWAYS CONDUCT YOURSELF IN A SPORTSMAN-LIKE MANNER.**

ALWAYS BE AWARE THAT YOUR ACTIONS WILL BE UNDER THE SCRUTINY OF OTHER MEMBERS OF THE PUBLIC WHO MAY NOT SHARE YOUR ENTHUSIASM FOR AIR WEAPONS. BAD PRACTICES PROMOTE BAD PUBLICITY. DO NOT JEOPARDISE YOUR FUTURE ENJOYMENT BY MISUSING THIS WEAPON.

Contents of Box.

- 1 x TDR rifle consisting of :
 - 1 x Moderator.
 - 1 x Fore end action including 1 magazine.
 - 1 x Rear stock.
- 1 x Tool kit consisting of :
 - 1 x Female adaptor.
 - 1 x 1.5mm Allen key.
 - 1 x 2.5mm Allen key.
 - 1 x 4mm Allen key.
- 1 x Manual.

THIS AIRGUN IS INTENDED FOR USE BY THOSE 18 YEARS OF AGE OR OLDER.



WARNING!

Not a toy. Adult supervision required. Misuse or careless use may cause serious injury or death. May be dangerous up to 1,000 yards.



WARNING!

Do not inhale dust from lead pellets or put lead pellets in the mouth. Wash hands after handling lead. Lead pellets contain lead, a chemical known to the State of California to cause cancer and birth defects (or other reproductive harm).



WARNING!

Keep the air rifle in the ON SAFE position until you're ready to shoot, then push the safety to the OFF SAFE position.



WARNING!

Keep your finger off the trigger while cocking the air rifle or with the barrel in the downward position. Failure to do so may permanently damage your air rifle. Do not shoot without a pellet in the chamber (dry fire). This may permanently damage your air rifle.



WARNING!

Use the correct pellet size according to your Air Arms rifle model. Never reuse pellets. The use of any other kind of ammunition can cause injury to you or damage to the air rifle.



WARNING!

Do not assume that the gun is unloaded if it fails to fire properly!



WARNING!

Never leave your gun loaded. Do not store it loaded.

IMPORTANT INFORMATION, PLEASE READ

Before leaving the factory this rifle was Q.A. inspected and test fired using Air Arms PELLETS to check operation and final adjustment.

It was dispatched in a sealed purpose designed box with a contents label on the lid. Air Arms may not be responsible for any damage to the contents or missing items if the box is not original, if it is damaged or the seals are not intact.

Air Arms cannot be held responsible for damage or missing items due to transit damage, mishandling or being tampered with after leaving the factory.

If this rifle is not received in the original box with the seals intact, please examine carefully for any damage, missing tools or documentation.

In the first instance any problems or complaints regarding this product should be referred to the supplier.

The air cylinder is a highly pressurised unit that must **not** be modified in any way. Serious personal injury may result if this, and the advice below is not followed.

Do **not** pressurise the cylinder if there are any surface abrasions or dents. Contact Air Arms for advice.

Do **not** store the rifle in places with, or near sources of high temperature such as fires or boilers.

Do **not** attempt to dismantle when pressurised.

Do **not** pressurise beyond the stated filling pressure (see filling instruction section). Damage caused by such action is **not** covered by the manufacturers warranty.

Only use clean, filtered and dry compressed air. **Never** use any other gas, particularly industrial or welding gases such as oxygen, carbon dioxide, acetylene, hydrogen, argon, etc.

If compressed air is being used other than from a diving shop, the inside of the cylinder should be inspected for corrosion at least annually. If in doubt contact Air Arms for advice.

In any event the cylinder should be inspected every two to three years depending upon usage. Air Arms can provide this service at a reasonable cost.

To maintain this rifle in good working order it should be serviced annually by a competent gunsmith, your supplier may be able to provide this service or contact air arms.

A reasonable amount of advice will be provided to enable the end user to service their own rifle, however this is at the discretion of Air Arms and may not be given in all cases.

The velocity of this rifle has been set using Air Arms field pellets. If any other make or type of pellet is to be used the rifle must be re-tested with the pellet that is to be used, to ensure the muzzle energy is within the limits determined by current legislation.

Due to the nature of hand pumps and their relative inefficiency in removing moisture from the compressed air, the chances of corrosion damage to the cylinder and other internal components are increased. Therefore the rifle should be regularly serviced and/or checked for any signs of damage by a competent gunsmith.

Air Arms recommend using a dry pack filter kit on any hand pumps used to fill our air rifles.

If accessories not manufactured by Air Arms are used on this rifle, Air Arms can not be held responsible for any loss of performance.

Contact your supplier or Air Arms for any advice on this matter.

IMPORTANT INFORMATION - Continued

CHECKING VELOCITY

- 1> Use a reliable chronograph to check velocity, (the formula below requires the reading to be in feet per second - FPS)
- 2> Use fine measurement scales to weigh the pellet, If scales are unavailable the pellet weight may be stated on the pellet container lid or contact the supplier. (The formula requires the weight to be in grains). To convert from grams to grains multiply by 15.432, i.e. 0.69 grams x 15.432 = 10.65 grains.
- 3> To find the muzzle energy in ft/lbs use the formula $(FPS \times FPS \times Grains) / 450240$, i.e. $(700 \times 700 \times 10.65) = 5218500$ divide by 450240 = 11.59.

CURRENT LEGISLATION LIMITS NON-FAC HOLDERS TO AIR RIFLES WITH A MAXIMUM OF 12ft/lbs MUZZLE ENERGY.

WARNING! IT IS A VERY SERIOUS OFFENCE TO BE IN POSSESSION OF AN AIR RIFLE THAT YOU ARE NOT CERTIFICATED FOR. CONVICTION CAN RESULT IN CONFISCATION OF YOUR RIFLE, A HEAVY FINE OR IMPRISONMENT, EVEN A COMBINATION OF ALL THREE.

Do **not** store this rifle in a damp place such as garden shed or garage.

Do **not** store this rifle in a plastic or pvc gun bag without first applying a surface corrosion inhibitor.

Always ensure the loading bolt is fully closed before firing.

******* LIMITED LIABILITY WARRANTY *******

This product is warranted to the retail customer for 12 months from date of purchase against defects in materials and workmanship and is transferable to any subsequent owner.

Proof of purchase is required to receive warranty repairs, retain your purchase invoice and return the warranty registration card as soon as possible after purchase. The warranty card must show the dealer/supplier name and address and date of purchase.

What is covered

Replacement parts & labour on a 'back to base' basis, return transportation to the consumer (mainland uk only).

What is not covered

Transportation from the consumer to Air Arms.

Damage caused by misuse, abuse, lack of routine maintenance, transit damage between the dealer/supplier and the consumer or unauthorised disassembly.

Parts subject to normal wear and tear.

Any other consequential cost incurred by the consumer.

Return transportation to consumers outside mainland uk.

No warranty is implied as to the fitness for any particular purpose.

AIR ARMS RESERVE THE RIGHT TO ALTER THE CONSTRUCTION, APPEARANCE OR PERFORMANCE OF ANY PRODUCT WITHOUT PRIOR NOTIFICATION. ALL ILLUSTRATIONS ARE FOR INFORMATION PURPOSES ONLY AND DO NOT NECESSARILY SHOW THE EXACT MODEL THAT WAS PURCHASED.

GENERAL MAINTENANCE AND LUBRICATION

MAINTENANCE

Fixings

Regularly check the tightness of all fixings. However do **not** be tempted to over tighten as some parts are made from aluminium and stripped threads may result. Stripped threads are not covered by the manufacturers warranty.

Barrel

For ultimate accuracy, clean and re-lube the barrel frequently. It is difficult to advise how often is best for every circumstance, but every 250 shots is not too often if the desire is to keep the barrel in the best possible condition.

The correct materials are very important. Air Arms only use products made by Napier. Listed below is the Napier product and a more generally available alternative. If possible use Napier for the best results.

<i>CLEANER :</i>	<i>'NAPIER GUN CLEANER', ALTERNATIVELY WHITE SPIRIT.</i>
<i>OIL :</i>	<i>'NAPIER GUN OIL', ALTERNATIVELY '3 IN 1' OIL.</i>
<i>PULL-THROUGH PAD :</i>	<i>'NAPIER RIFLE CLEAN', ALTERNATIVELY SOFT COTTON CLOTH.</i>
<i>PULL-THROUGH LINE :</i>	<i>'NAPIER PULL THROUGH KIT', ALTERNATIVELY 20lb FISHING LINE.</i>

As a rule cleaners and oils intended for shotguns and small/fullbore weapons are not suitable.

- 1> Cut a piece of line three times the length of your barrel, fold in half and tie ends together. Remove silencer if fitted. Open loading bolt.
- 2> Feed un-knotted end down barrel from the muzzle end until folded end protrudes about 50mm.
- 3> Cut a 100mm length of 'rifle clean' or 100x50mm piece of cloth and pass it between the protruding loop. Spray the pad with 'gun cleaner' or white spirit, turn the rifle upside down and pull the line back through the barrel slowly.
- 4> Repeat steps 2&3 until the pad is clean.
- 5> Repeat steps 2&3 once more without any cleaner on the pad to dry the barrel.
- 6> Repeat steps 2&3 once more with the pad sprayed with 'gun oil' or 3 in 1 oil.

Important : The reason for turning the rifle upside down is to prevent excess cleaner/oil from passing down the transfer port into the firing valve chamber.

Lubrication

Lubrication of the internal mechanism is not covered in this handbook. This is best performed by a competent gunsmith or the factory and in any case should not be required until the annual service.

Apply a small dab of grease on the loading bolt and work-in by moving the bolt forwards and backwards. Wipe off excessive grease. Preferred grease is 'Napier g95 gun grease'

On return from every shooting session, wipe all over the exterior with an oily rag to preserve the surface finish during storage.

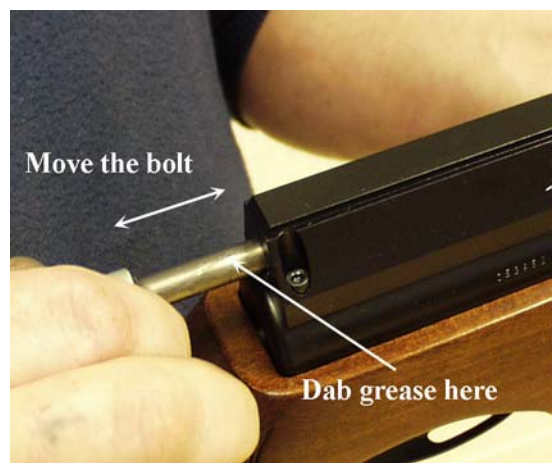

OPERATING INSTRUCTIONS

Cocking

Hold securely in one hand and with the other turn the loading bolt and pull backwards until the first restriction is felt. Pull back further until the trigger mechanism engages. This can be determined by the trigger blade 'kicking' forward at the end of the cocking stroke.

If the bolt is gripped as in the illustration with the thumb on the other side of the bolt knob, the cocking action is much smoother.



Note ! It is very important that the loading bolt is pulled back to the correct position in one positive motion. The magazine indexes to the next pellet position as the bolt is retracted and it is possible for a partial index if the bolt is not pulled back fully.

If you find the mechanism has not cocked completely but the magazine has indexed, re-cock but before closing the bolt, remove the magazine and manually index it back to the empty chamber. Replace the magazine and fire as normal. If this procedure is not followed it is likely that you will load a second pellet into the barrel.



The rifle is now cocked and loaded, **treat with caution.**

MOUNTING/DEMOUNTING THE MAGAZINE & PELLETS

Demounting

Fully cock the rifle, grip the magazine as fig.1 and slide out of the bolt housing without lifting. **Do not** attempt to lift vertically as damage to the indexing spring will result.

Mounting

Fully cock the rifle, grip the magazine as fig.2 and slide in the bolt housing applying downward pressure with the fore finger to keep the base of the magazine against the bottom of the slot in the bolt housing. Take care not to damage the indexing spring.



Loading Pellets

Hold the magazine as in fig.3 and drop a pellet into the chamber. Manually index to the next empty chamber as in fig.4 and repeat until the magazine is full. Finally line up the red dot on the pellet carrier with the 'V' notch on the clear magazine cover.

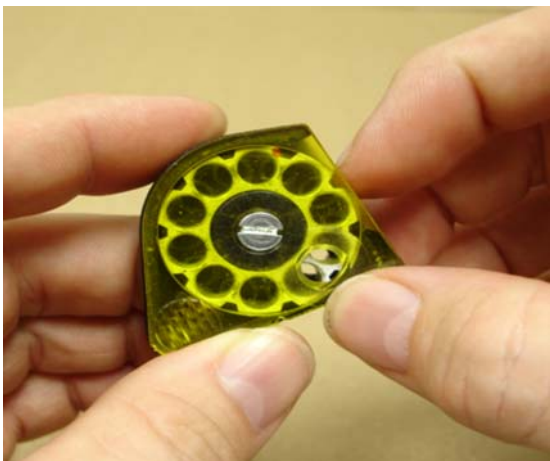
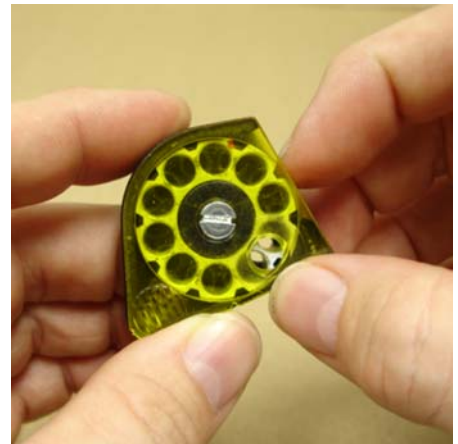
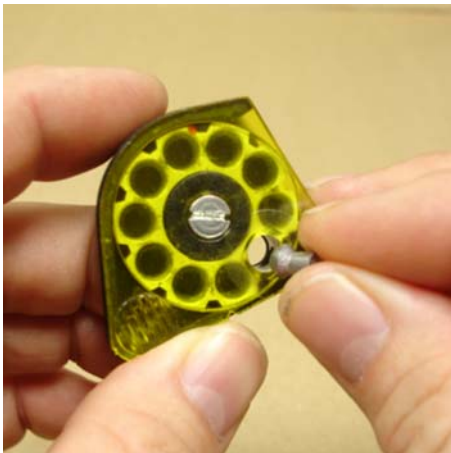

Be very careful not to damage the indexing spring when demounting or mounting the magazine. Follow the instructions carefully.

WARNING *The rifle should only be fired when the magazine is fitted in the breech or damage to the seal carrier may occur.*

TRIGGER ADJUSTMENTS

All S400/410 models all have the same trigger mechanism. It is a two stage unit with adjustment to both stages plus a weight of pull adjustment. It is easy to upset the balance between the two stages and make the trigger inoperable if incorrectly adjusted.

If you have no experience of adjusting two stage triggers seek guidance or leave the trigger as set by the factory.

Note ! Incorrectly adjusted trigger mechanisms are not covered by the manufacturers warranty. It is not possible to test this rifle with an incorrectly adjusted trigger, therefore all triggers leave the factory with correct adjustment.

Warning !

Please note that it is possible to stop the safety button working with incorrect trigger adjustment. An incorrectly adjusted trigger can make the rifle unsafe to handle.

Description of Operation

The S400/410 range of rifles have a true two stage trigger mechanism. This means that as the trigger is pulled the bottom sear gradually disengages with the top sear until the two disengage completely and the rifle goes off. If the pressure on the trigger is released at any point before full disengagement, the bottom sear will automatically return back to full engagement. This type of trigger allows very fine but safe operation because it is the release of the 2nd stage that actually makes the rifle fire. This arrangement is vastly superior to pseudo two stage triggers where the first stage is just a pivoting trigger blade that does not move sears. The down side is that they are more difficult to adjust correctly.

Adjustment

There are three adjuster screws, A-B-C.

The weight of pull adjuster (A) is located in the front of the trigger guard. Clockwise rotation increases pull weight. If adjusted too far the spring will become coil-bound and prevent trigger operation.

The second stage adjuster (C) is the rear screw located in the trigger blade. This screw determines the exact point that the 2nd stage starts. If the 1st stage screw is incorrectly adjusted this screw may not have any effect.

The first stage adjuster (B) is the front screw located in the trigger blade. This screw determines the length of travel before the 2nd stage starts. Clockwise adjustment reduces the first stage travel.

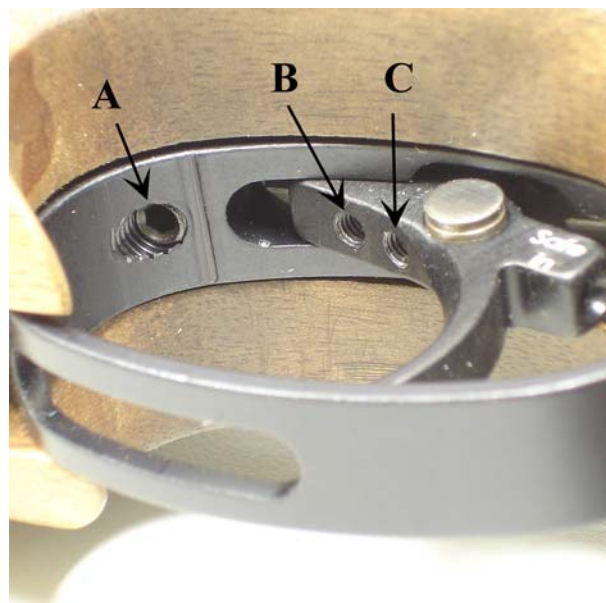

Manual Safety

This rifle is fitted with a manual safety button located in the trigger blade.

To make the rifle safe the button must be pressed in on the side of the trigger with the words 'safe in' until the button is flush with the side of the trigger blade.

Please note that it is possible to stop the safety button working with incorrect trigger adjustment.



With the button pressed in the rifle is safe.



With the button out the rifle is now ready to fire.

FILLING INSTRUCTIONS

NOTE ! ONLY USE CLEAN, DRY AND FILTERED COMPRESSED AIR, PREFERABLY FROM A DIVING SHOP. OVER PRESSURISATION MAY DAMAGE THE CYLINDER BEYOND REPAIR.

First the female part of the filling kit (this was supplied with the rifle) must be fitted to your filling equipment. The female part (S475) has a 1/8th BSP male thread that screws directly into the hose of your pump or bottle.

Next remove the dust cover from the end of your rifle.



This is achieved by unscrewing the cover in an anti-clockwise direction.

Once the connector is exposed the female part of the filling kit can be placed on the male and pressed all the way on making sure that the 'O' rings on the male part are covered. Once the female part is pushed on to the male, twist it to lock it into place.



Using hand pumps.

The procedure for using hand pumps is the same as for bottle. It is more important to turn the female on the gun to lock it in place.

When using the pump it must be remembered that the first few pumps are filling the hose and NOT the gun. When the pressure in the hose equalises to that in the gun, the gun will start to fill.

It can take some effort to fill the gun using a pump and we recommend using the pump to top up instead of filling from empty.

With the female in place the gun can now be filled.

If the rifle is empty the mechanism will need to be cocked to allow the firing valve to close. If the rifle is not cocked when the bottle is opened or the pump used, the air will past the valve and exhaust through the barrel.

Check that the bleed valve on the filling equipment is closed (turn clockwise to close) then **slowly** open the main valve on bottle or start using the pump. The pressure in the hose will equalise and then the rifle will start to fill.

If you are filling your rifle from empty there may be some air exhausted through the barrel until the air pressure is sufficient to over come the firing valve spring (S306) this will happen at approximately 50 bar (750psi).

The filling pressure of the TDR is 190 bar (2755psi). Filling to a higher pressure will **not** increase either power or number of shots. Over filling will **lower** the power and may cause irreparable damage to the cylinder.

Once the filling pressure has been reached, close the valve on the bottle or stop pumping, open the bleed valve on the filling kit (to vent the hose, if you do not vent the hose you will not be able to remove the female from the rifle). Now the female connector can be removed from the rifle and end cap (S483) can be replaced over the male connector ensuring not to overtighten.



The TDR range of rifles are fitted with a pressure indicator mounted on the underside of the rifle just in front of the stock screw. This provides the user with a visual check on the amount of air remaining in the cylinder this indicator should not be used during the filling process as the needle reaction speed has been slowed to prevent damage whilst filling. After filling the needle can take several seconds to synchronise with the air in the cylinder. The picture below shows a rifle with just over 150 bar of pressure. Although every gun is slightly different the recommended refill pressure for the TDR is between 100 and 110 bar.



NOTE: On the front of the cylinder is an engraved warning reading....

*READ MANUAL. MFP 200bar. MSP 200bar. DOM **/**/** **.
INSPECT ANNUALLY.*

*MFP = Maximum Filling Pressure. The pressure is stated.
MSP = Maximum Safe Pressure. The pressure is stated.
DOM = Date of Manufacture. The date is stated.*

MAGAZINE CLIP

Housed in the cheek piece are two clips used to hold spare magazines. The magazines are pushed into the spring clip which holds them securely until they are required.

To remove the magazines simply pull them from the clip.

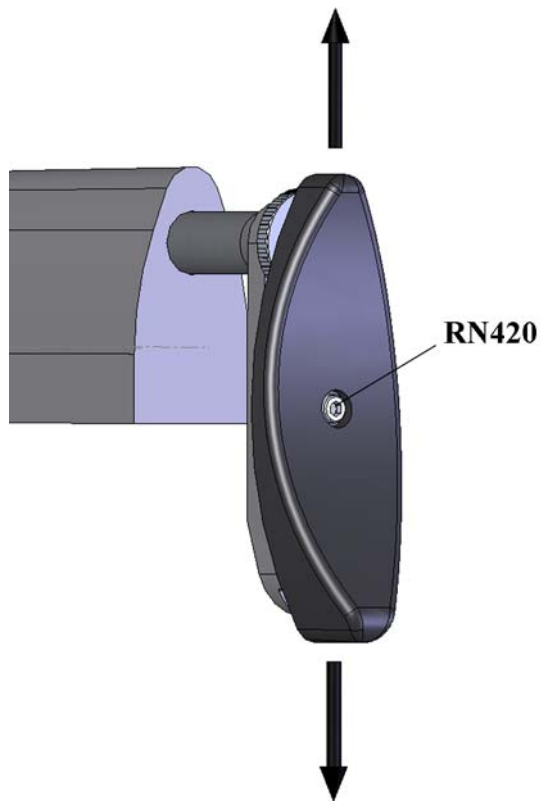

ADJUSTABLE BUTT PAD

The butt pad on the TDR is adjustable in the vertical plane. This is achieved by loosening the butt pad screw (RN420) slightly using a 4mm allen key (supplied) and sliding the pad to the required position then retighten the screw, always being careful not to overtighten.

ASSEMBLY AND DISSASSEMBLY

One of the main features of the TDR is the fact that it can be broken down and carried or stored in a smaller case.

The disassembly of the rifle is very easy and can be carried out without the use of tools or special knowledge. The rifle breaks down into three parts the moderator, the fore-end and the butt end.

The moderator is removed by loosening the knurled screw (ks581) in the underside of the moderator. The moderator will then slide off of the barrel.



To remove the rear stock from the rifle, the fixing wheel at the back of the stock (KS460) must be turned anti-clockwise.

When this is loosened fully the rear stock will come away from the fore-end.



Note: Without the rear stock fitted to the rifle the power is greatly reduced. This is to ensure the the TDR complies with current UK laws concerning air pistols. For this reason the rifle should **NOT** be fired without the rear stock fitted.

When the rifle is in its disassembled state it can be fitted into the case supplied with the gun.



RE-ASSEMBLY

The moderator can simply be slipped on to the barrel and the knurled screw pinch tight. Do not over tighten the screw as this can put a burr on the barrel which could make removing the moderator difficult.

To refit the rear stock there are four pins that have to be lined up with four corresponding holes.

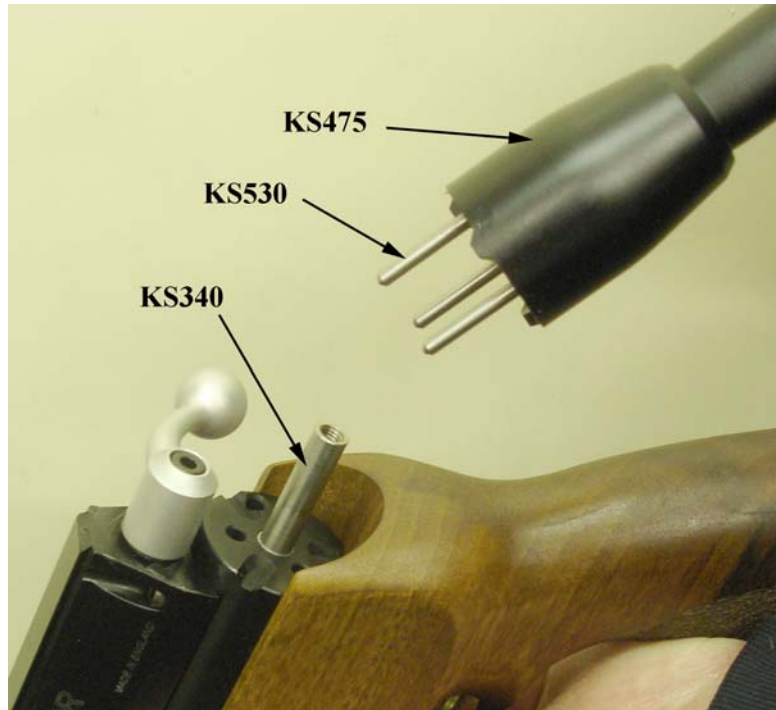

Part no. KS340 has to line up with the hole in the center of the cover on the front end of the stock piece (KS475), a small amount of pressure can then be applied to the rear stock so that the three locating pins (KS530) push through the corresponding holes (marked 1 on the above picture) in the striker body.

Whilst pushing the rear stock and fore-end together turn the fixing wheel (KS460) clockwise until the two parts are pulled together and no movement can then be detected.



The case that is supplied with the TDR is equipped with shoulder straps which can be used to carry the case on your back. These straps are fixed to the case using spring clips that can be squeezed to release them from the D rings on the case.



SAFETY

You and others with you should always wear shooting glasses to protect your eyes.

Always aim your air rifle in a SAFE DIRECTION. When you are sure of your target and backstop and the area around the target is clear, take the air rifle OFF SAFE and squeeze the trigger to fire.

Do not shoot at hard surfaces or at the surface of water. The pellet may bounce off or ricochet and hit someone or something you had not intended to hit.

Always choose your target carefully. It is best to shoot at paper bullseye targets attached to a safe backstop. Your backstop should be checked for wear before and after each use. Replace your backstop if the surface is worn or damaged or if a ricochet occurs.

Your rifle is suited for indoor and outdoor use. Always remember to place your target carefully. THINK about what you will hit if you miss the target.

Do not attempt to disassemble or tamper with your air rifle. Contact Air Venturi at 216-292-2570 for repair.

Do not put the air rifle away while it is loaded or cocked.

REPAIR SERVICE

**If your rifle needs to be repaired,
contact Air Venturi at 216-292-2570.**

ITEM NO.	PART NUMBER	DESCRIPTION	QTY.	ITEM NO.	PART NUMBER	DESCRIPTION	QTY.
1	S312	TRIGGER CHASSIS	1	17	S524	SAFETY BUTTON SCREW	1
2	TX398	3x11.8 ROLLER	1	18	TX381	WEIGHT SCREW	1
3	S326	2x11.8 ROLLER	6	19	S319	WEIGHT OF PULL SPRING	1
4	S320-2	TOP SEAR	1	20	S430	COVER PLATE	1
5	S328	BS005 O RING	1	21	S324	M3X5 CHEESE HEAD	1
6	S325-2	BOTTOM SEAR	1	22	S324	M3X5 CHEESE HEAD	1
7	S321-2	MIDDLE SEAR	1	23	KS310AT	STRIKER BODY (ANTI-TAMPER)	1
8	S329	BS004 O RING	2	24	S322	M4x12 CSK SOC	1
9	S495	TOP SEAR SPRING	1	25	TX236	BOLT HSE SCREW	1
10	S496	M3x6 CAP	1	26	S316	TRIGGER GUARD SCREW LG	1
11	S420S	TRIGGER BLADE	1	27	TX460	TRIGGER GUARD SCREW SM	1
12	S421	TRIGGER SCREW	2	28	S315	TRIGGER GUARD	1
13	TX432	LOCKING PAD	1	29	RN170	BISEL PIN	1
14	S521	SAFETY BUTTON	1	30	S425	2x15.8 Roller	1
15	S522	SAFETY BUTTON BALL	1	31	KS311	LOCKING PIN	1
16	S523	SAFETY BUTTON SPRING	1				

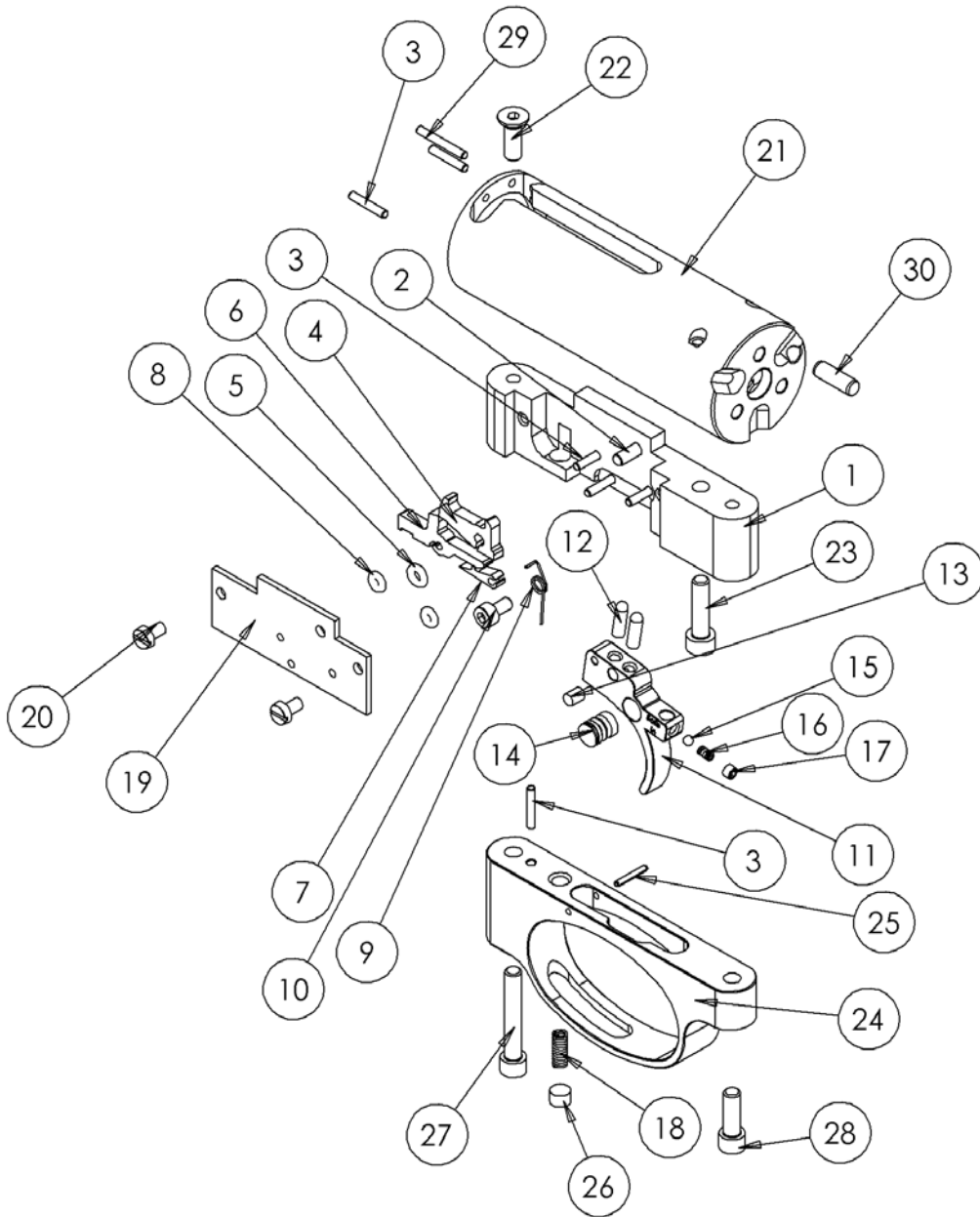

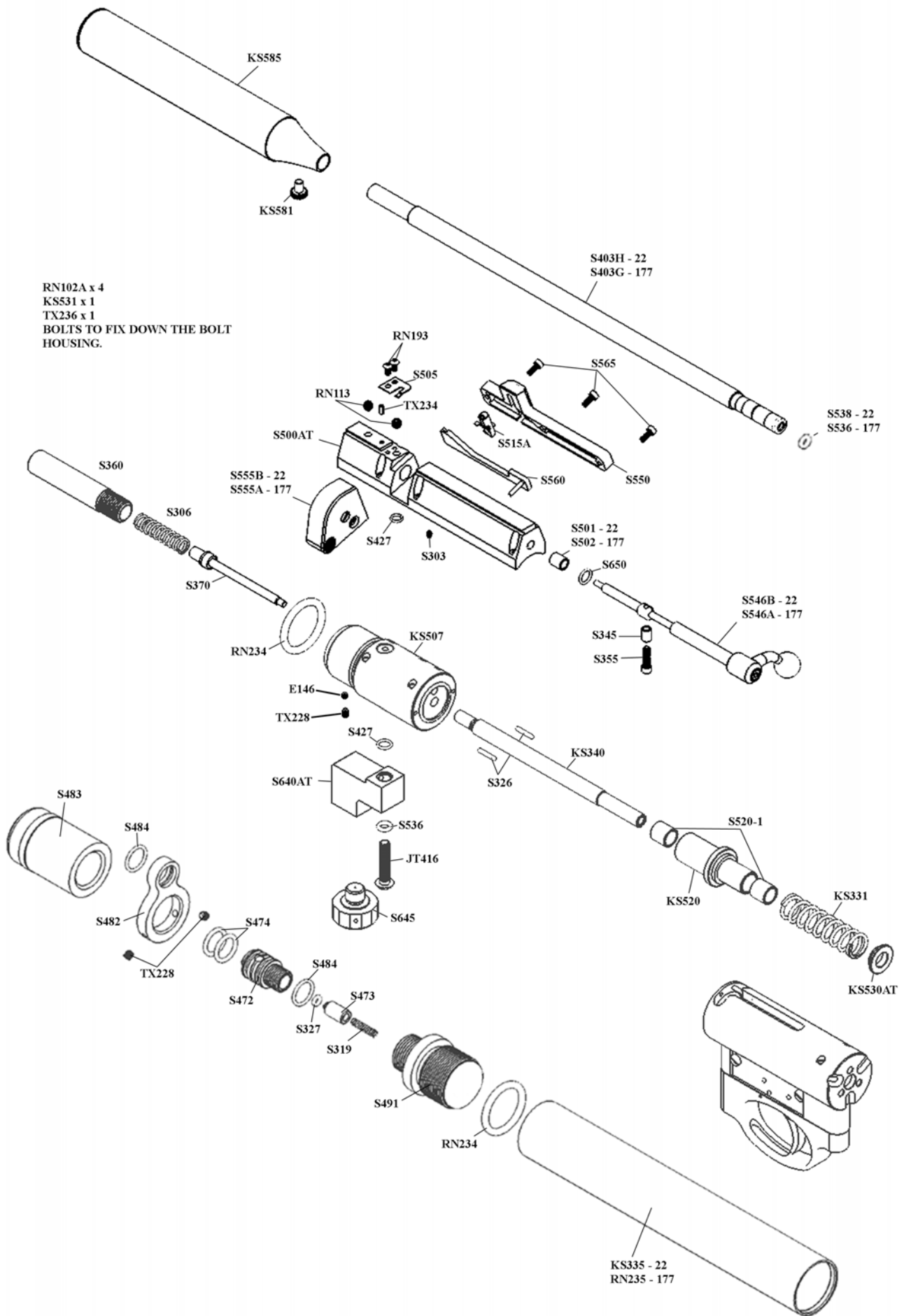

PART LIST <> TDR410

PART NO.	DESCRIPTION.	QTY	PART NO.	DESCRIPTION.	QTY
E146	BALL	1	S427	6x1 'O' RING	2
JT416	GAUGE MOUNT SCREW	1	S472	MALE ADAPTOR	1
KS331	MAINSRING	1	S473	FILLING VALVE	1
KS335	CYLINDER TUBE .22	1	S474	12x2 'O' RING	2
KS340	GUIDE ROD	1	S482	FRONT CLAMP	1
KS483	END CAP	1	S484	12x1.5 'O' RING	2
KS507	FIRING VALVE BODY	1	S491	FILING VALVE BODY	1
KS520	STRIKER	1	S500AT	BOLT HOUSING	1
KS530AT	REAR SPRING GUIDE	1	S501	BOLT HOUSING BUSH .22	1
KS531	BOLT HSE SCREW	1	S502	BOLT HOUSING BUSH .177	1
KS581	MODERATOR SCREW	1	S505	RETAINING CLIP	1
KS585	MODERATOR	1	S515A	MAG INDEXING POST	1
KS630	FOREEND STOCK	1	S520-1	STRIKER BUSH	2
RN102A	M3 x 16 SCREW SOC CAP	4	S536	BS008 'O' RING	2
RN113	M5x5 RETAINING SCREW	2	S538	BS009 'O' RING	1
RN193	M3x6 BUTTON SCREW	2	S546A	LOADING BOLT ASSY 177	1
RN234	CYLINDER 'O' RING	2	S546B	LOADING BOLT ASSY 22	1
RN235	CYLINDER .177	1	S550	SIDE PLATE	1
S303	M3x4 LOCKING SCREW	1	S555A	MAGAZINE ASSY 177	1
S306	FIRING VALVE SPRING	1	S555B	MAGAZINE ASSY 22	1
S319	WEIGHT ADJUSTER SPRING	2	S560	CAM PLATE	1
S326	2x11.8 ROLLER	2	S565	M3x8 SCREW	3
S327	BS005 'O' RING	1	S640AT	GAUGE MOUNT	1
S345	SLEEVE	1	S645	GAUGE	1
S355	M4x14 LOADING BOLT SCRW	1	S650	8x1 'O' RING	1
S360	POT	1	TX228	M4x4 SCREW	3
S370	FIRING VALVE ASSY	1	TX234	3/32x1/4 BISSEL PIN	1
S403H	BARREL ASSY	1	TX236	BOLT HSE SCREW	1

PART LIST <> TDR410 REAR STOCK

PART NO.	DESCRIPTION.	QTY	PART NO.	DESCRIPTION.	QTY
KDT005	M5 Nut	1	KS627	M4 Washer	2
KS440	Cheek Piece Tube	1	KS630A	Cheek piece	1
KS457	Butt Pad Base Plate	1	KS631	Mag Spring	2
KS460	Wheel	1	RN102A	M3x16 SOC CAP Screw	6
KS465	Rear Stock Fixing Screw	1	RN420	M5x25 SKT CAP ST/ST	1
KS475AT	Cover	1	RN445	No 6x3/8 Pozi CSK	4
KS531	Location Pin 3x28	3	RN455	Butt Pad	1
KS626	M4x20 SOC CAP Screw	2	RN462	Butt Pad Locking Plate	1

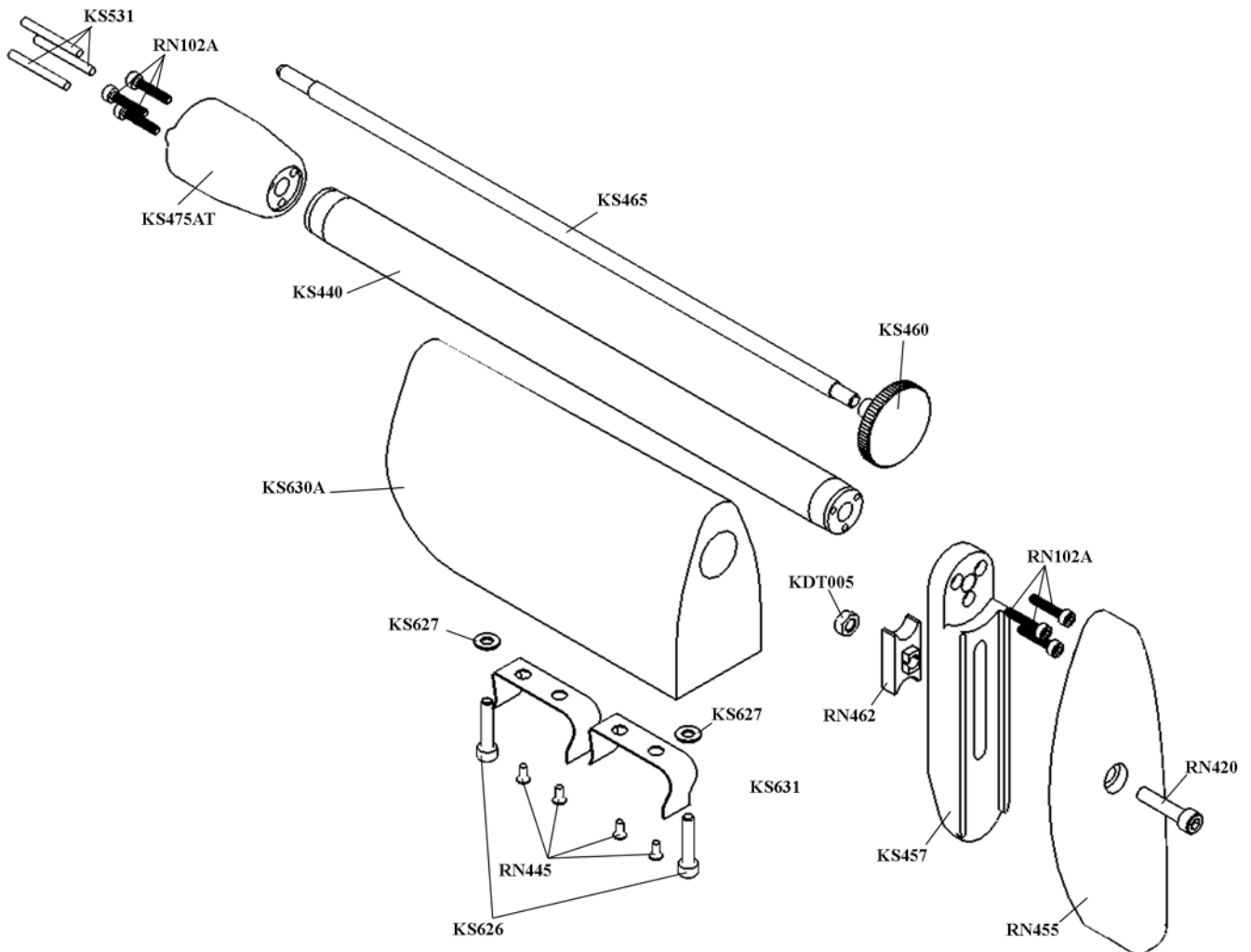

WARRANTY

Limited One-Year Warranty

This product is warranted to the retail consumer for one year from date of retail purchase against defects in material and workmanship and is transferable.

What is covered:

Replacement parts and labor. Transportation charges to consumer for repaired product.

What is NOT covered:

Transportation charges to Air Venturi for defective products. Damages caused by abuse or failure to perform normal maintenance. Any other expense. CONSEQUENTIAL DAMAGES, INCIDENTAL DAMAGES OR INCIDENTAL EXPENSES INCLUDING DAMAGE TO PROPERTY. SOME STATES DO NOT ALLOW THE EXCLUSION OR LIMITATION OF INCIDENTAL OR CONSEQUENTIAL DAMAGES, SO THE ABOVE LIMITATION OR EXCLUSION MAY NOT APPLY TO YOU.

Warranty claims:

Warranty claims for U.S. and Canadian Customers:

Please return product to Air Venturi. Call Air Venturi at 216-292-2570 before returning any product.

Implied warranties:

ANY IMPLIED WARRANTIES, INCLUDING THE IMPLIED WARRANTIES OF MERCHANTABILITY AND FITNESS FOR A PARTICULAR PURPOSE, ARE LIMITED IN DURATION TO ONE YEAR FROM DATE OF RETAIL PURCHASE. SOME STATES DO NOT ALLOW LIMITATIONS ON HOW LONG AN IMPLIED WARRANTY LASTS, SO THE ABOVE LIMITATION MAY NOT APPLY TO YOU.

To the extent any provision of this warranty is prohibited by federal, state or municipal law which cannot be preempted, it shall not be applicable. This warranty gives you specific legal rights, and you may also have other rights which vary from state to state and country to country.

Air Venturi

AirVenturi.com • 216-292-2570

WARNING!

DO NOT TRY TO DISASSEMBLE THE GUN. Your rifle needs special tools and Air Arms parts in order to be repaired. If you disassemble it, you may not be able to properly reassemble it. Air Arms does not assume any warranty liability under such circumstances.

Notes