



Model 795

.177 Caliber (4.5 mm) Spring Airgun

OWNER'S MANUAL

READ ALL INSTRUCTIONS AND WARNINGS IN THIS MANUAL BEFORE USING THIS AIRGUN

Crosman Corporation
Routes 5 & 20,
P.O. Box 308
E. Bloomfield, NY 14443
www.crosman.com
1-800-7AIRGUN

P/N 795-515

WARNING: Not a toy. This airgun is recommended for adult use only. Misuse or careless use may cause serious injury or death. May be dangerous up to 475 yards (435 meters).

YOU AND OTHERS WITH YOU SHOULD ALWAYS WEAR SHOOTING GLASSES TO PROTECT YOUR EYES.

READ ALL INSTRUCTIONS BEFORE USING.

BUYER AND USER HAVE THE DUTY TO OBEY ALL LAWS ABOUT THE USE AND OWNERSHIP OF THIS AIRGUN.

THIS AIRGUN IS INTENDED FOR USE BY ADULTS ONLY.

WARNING: Lead pellets. Do not inhale dust or put pellets in mouth. Wash hands after handling. This product contains lead, a chemical known to the State of California to cause cancer and birth defects (or other reproductive harm.)

Congratulations and thank you for purchasing the CROSMAN® Model 795 .177caliber (4.5-mm)-pellet airgun. Please read this owner's manual completely. And remember, this airgun is not a toy. Treat it with the same respect you would a firearm. Always carefully follow the safety instructions found in this owner's manual and keep this manual in a safe place for future use.

If you have any questions regarding your new airgun, please contact Crosman at 1-800-7AIRGUN, 585-657-6161 or www.crosman.com and ask for customer service.

Operating Procedures

- Section 1. Learning the Parts of Your New Airgun
- Section 2. Operating the Safety
- Section 3. Cocking, Loading and Unloading Your Airgun
- Section 4. Aiming and Firing Safely
- Section 5. Removing a Jammed Pellet

- Section 6. Maintaining Your Airgun
- Section 7. Reviewing Safety

1. Learning the Parts of Your New Airgun.

Learning the names of the parts of your new airgun will help you to understand your owner's manual. Use this manual to increase your enjoyment of this airgun.

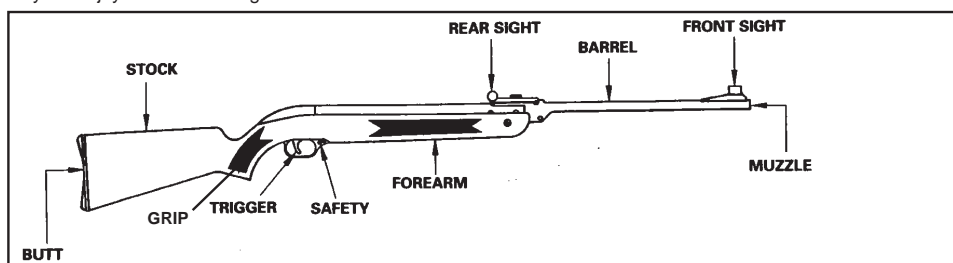

2. Operating the Safety

2.1 To Put the Airgun "ON SAFE":

WARNING: Keep the airgun in the "ON SAFE" position until you are actually ready to shoot. Then push the safety to the "OFF SAFE" position.

- Locate the safety directly in front of the trigger.
- Push the safety from the left side all the way in (Fig. 1). The safety is not "On Safe" unless it is pushed all the way in and the RED ring around the left side of the safety is NOT showing.

Like all mechanical devices, an airgun safety can fail. Even when the safety is "On Safe", you should continue to handle the airgun safely. NEVER point the airgun at any person. NEVER point the air gun at anything you do not intend to shoot.

2.2 To Take the Airgun "OFF SAFE":

- Push the safety from the right side all the way in. When you can see the RED ring around the left side of the safety, the airgun is "Off Safe" and can be fired.

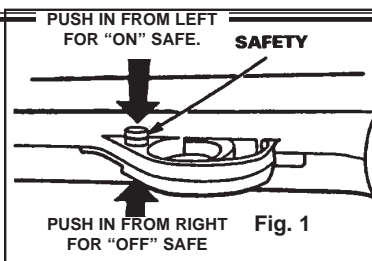

3. Cocking, Loading and Unloading Your Airgun

3.1 Cocking Your Airgun

- Do not cock your airgun until you are ready to load and fire, since the only way to uncock your airgun is to fire it. Firing your gun without a pellet in the chamber (dry firing) may cause damage to your airgun.
- Put the airgun "ON SAFE" (SECTION 2).
- Keep the airgun pointed in a safe direction.
- Grasp the airgun by the grip with one hand and place your other hand around the barrel.
- Pull the barrel downward as shown in Figure 2. Do not pull past this point and do not use excessive force or speed when cocking your airgun.

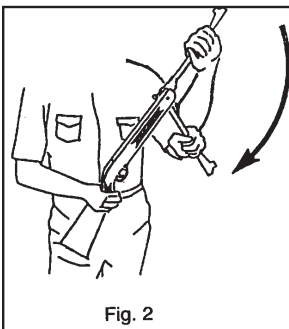

WARNING: Make sure you do not touch the trigger or push the safety to the "OFF SAFE" position.

WARNING: Make sure you do not pull the trigger while cocking the airgun or with the barrel in the down position. This may cause serious damage to the airgun.

- Some find it easier to cock the airgun when bracing the butt of the airgun against your leg (Fig. 2).
- Be careful not to pinch your hand or fingers in the hinge area of the airgun.

3.2 Loading Your Airgun

CAUTION: Do not fire your airgun without a pellet in the chamber (dry fire). This may permanently damage your airgun.

- With the barrel in the open position, after it has been cocked, place one .177 caliber pellet, nose forward, into the breech (Fig. 3). Make sure that the skirt of the pellet is flush with face of breech.
- Move the barrel back to its original position by pushing the barrel up until it locks (Fig. 4). Once again, be careful not to pinch your hands or fingers. Be sure the airgun is "ON SAFE" and pointed in a safe direction.

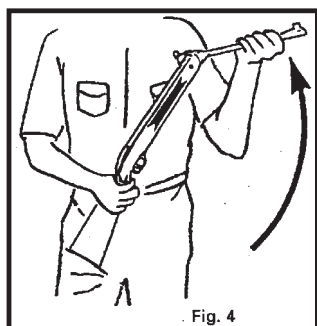
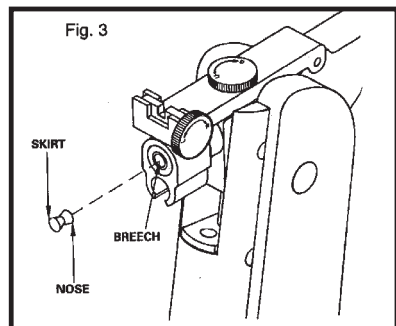

WARNING: Your airgun is now loaded and ready to fire. Keep the airgun "on safe" until you are ready to shoot. Do not point at anything you don't intend to shoot.

3.3 Unloading Your Airgun

Do not cock and load your airgun until you are ready to shoot since the only way to decock your airgun is to fire it in a safe direction following instructions in Section 4. REMEMBER, choose your targets carefully and be sure that the area around the target is clear. THINK what you will hit if you miss the target! Do not store your gun cocked or loaded. Use .177 caliber pellets only. Never reuse ammunition. Use of any other ammunition can cause injury to you or damage to the airgun.

4. Aiming and Firing Safely

4.1 Aiming and Firing the Airgun

- You and others with you should always wear shooting glasses to protect your eyes.
- Always aim your airgun in a SAFE DIRECTION.
- Do not shoot at hard surfaces or at the surface of water. The pellet may bounce off or ricochet and hit someone or something you had not intended to hit.
- Always choose your target carefully. It is best to shoot at paper bull's-eye targets which are attached to a safe backstop. A heavy blanket should be hung behind the backstop to prevent ricochet should you miss the backstop.
- Your backstop should be checked for wear before and after each use. Replace your backstop if the surface is worn or damaged or if a ricochet occurs.
- Your airgun is designed for target shooting. Always remember to place your target carefully. THINK about what you will hit if you miss the target.
- The airgun is correctly aimed when the front sight is positioned exactly in the notch of the rear sight. The top of the front sight blade should be even with the top of the notch in the rear sight. The bull's-eye should appear to rest on the top of the front sight (Fig. 5).
- When you are sure of your target and backstop, and the area around the target is clear, take the airgun "Off Safe" (See section 2.2) and pull the trigger to fire.

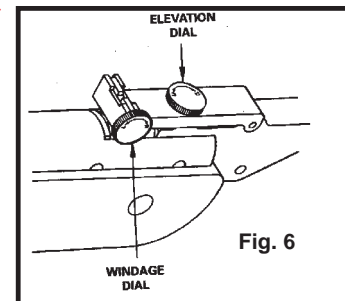
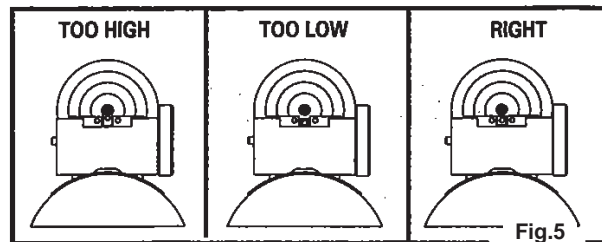

4.2 Sight Adjustment

- Elevation is set by means of the rear sight-elevating dial situated on the rear sight base. Turn the dial counterclockwise to make the pellet hit higher on the target and turn the dial clockwise to make the pellet hit lower on the target. (Fig. 6)
- Windage is set by turning the windage dial located on the right side of the sight. Turn the dial counterclockwise to make the pellet hit to the left on the target and turn the dial clockwise to make the pellet hit to the right on the target. (Fig. 6)

5. Removing a Jammed Pellet

- Put your airgun "ON SAFE" (Section 2).
- Do not reload the air rifle if a pellet is jammed.
- With the gun pointed in a SAFE DIRECTION, break the barrel open slightly (without pulling the barrel all the way down to the point that it cocks the action) and look down the breech to see if the gun is jammed.
- If it is jammed, insert a cleaning rod into the breech and push the jammed pellet out of the muzzle. Don't try to reuse that pellet (Fig. 7).
- CAUTION:** Do not cock the airgun during the removal of a jammed pellet unless you plan on continuing to shoot.
- Remember; do not fire your airgun without a pellet in the chamber (dry fire). This may permanently damage your airgun.
- Do not leave the airgun cocked. This will weaken the main spring and cause damage to your airgun.
- If you are not able to unjam your airgun by following the unloading procedure, take no further action. An Authorized Service Station will unjam your airgun (no cost during the warranty period).

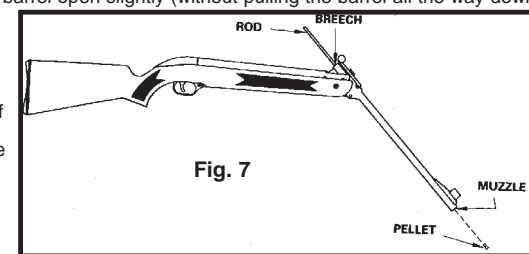

6. Maintaining Your Airgun

- To ensure that your air rifle maintains uniform power, it is important that you apply a drop of Crosman RMC OIL every few hundred shots into the compression chamber. (Fig. 8)
- CAUTION:** Do not attempt to disassemble your airgun. Do NOT MODIFY OR ALTER YOUR AIRGUN. Attempts to modify the airgun in any way inconsistent with this manual may make your airgun unsafe to use, cause serious injury or death, and will void the warranty.
- Always keep the airgun on safe until you are ready to shoot.
- If you drop your airgun, visually check to see that it works properly before you use it again. If anything seems changed, like a shorter or weaker trigger pull, this may mean worn out or broken parts. Call Crosman customer service for assistance before using your airgun again.
- CAUTION:** Use Crosman RMC OIL only and do not over-oil. To do so can cause possible damage to the gun and injury to the shooter and bystanders.

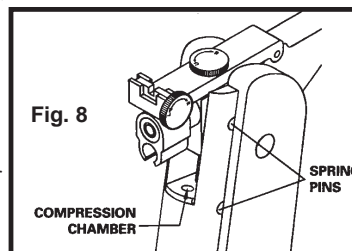

7. Reviewing Safety

- Never point the airgun at any person or at anything you do not intend to shoot.
- Always treat the airgun as though it is loaded and with the same respect you would a firearm.
- Always aim in a SAFE DIRECTION. Always keep the muzzle of the airgun pointed in a SAFE DIRECTION.
- Always keep the airgun on safe until you are ready to shoot.
- Always check to see if the airgun is "On Safe" and unloaded when getting it from another person or from storage.
- Always keep your finger off the trigger and out of the trigger guard until ready to shoot.
- You and others with you should always wear shooting glasses to protect your eyes.
- If your reading or prescription glasses are not safety glasses, make sure you wear shooting glasses over your regular glasses.
- Use the proper size pellet for your airgun. (.177 caliber or 4.5 mm)
- Never reuse ammunition.
- Do not shoot at hard surfaces or at the surface of water. The pellet may bounce off or ricochet and hit someone or something you had not intended to hit.
- Place the backstop in a location that will be safe should the backstop fail.
- Your backstop should be checked for wear before and after each use. All backstops are subject to wear and will eventually fail. Replace your backstop if the surface is worn or damaged or if a ricochet occurs.
- Do not attempt to disassemble or tamper with your airgun. Use an Authorized Service Station. Using unauthorized repair centers or modifying the function of your airgun in any way may be unsafe and will void your warranty.
- Always keep your CrosBlock® trigger block in place when storing this airgun. Store airgun in a secure location. (See CrosBlock instructions packaged with this airgun for assistance)
- Before you store your airgun, make sure that it is unloaded, not cocked, and that the airgun is "On Safe."

SPECIFICATIONS

Mechanism/Action	Spring	Sights	Front: Fixed ramp Rear: Fully Adjustable for Windage and Elevation
Caliber/Ammunition	.177 caliber .177 cal. (4.5 mm) Lead Airgun Pellet	Safety:	Cross bolt
Weight	4 lbs. 6 oz. (2 kg)	Velocity:	Up to 600 fps (182.9 mps)
Length	42 inches (106.7 cm)	Barrel:	Rifled Steel

PERFORMANCE

Many factors can affect velocity, including brand of projectile, type of projectile, lubrication, barrel condition and temperature.

REPAIR SERVICE

If your airgun needs repair, we recommend you take or send it to your nearest Crosman Authorized Service Station. DO NOT ATTEMPT TO DISASSEMBLE IT! Your airgun requires special tools and fixtures to repair it. Any disassembly or modification not performed by an Authorized Service Station will void the warranty.

A SPECIAL CUSTOMER SERVICE

Crosman Authorized Service Stations will unjam your airgun at no cost during the warranty period.

LIMITED ONE YEAR WARRANTY

This product is warranted to the retail consumer for one year from date of retail purchase against defects in material and workmanship and is transferable. To register the serial number of your airgun, please return the airgun registration form. The warranty is not conditioned on the return of the card. You should retain the original sales receipt as record of date of purchase.

WHAT IS COVERED

Replacement parts and labor. Transportation charges to consumer for repaired product.

WHAT IS NOT COVERED

Transportation charges to Authorized Service Station for product. Damages caused by abuse, modification or failure to perform normal maintenance - see Owner's Manual. Any other expense. CONSEQUENTIAL DAMAGES, INCIDENTAL DAMAGES, OR INCIDENTAL EXPENSES INCLUDING DAMAGE TO PROPERTY. SOME STATES DO NOT ALLOW THE EXCLUSION OR LIMITATION OF INCIDENTAL OR CONSEQUENTIAL DAMAGES SO THE ABOVE LIMITATION OR EXCLUSION MAY NOT APPLY TO YOU.

HOW TO OBTAIN WARRANTY PERFORMANCE

U.S. Customers: Locate nearest service station (see www.crosman.com or call Crosman customer service at 800-724-7486 for list of stations). The service station will give you details of how to proceed with sending the item in for repair. You must contact the station prior to shipping your product.

Canadian Customers: Contact Crosman Parts & Service- 611 Neal Drive Peterborough, ON K9J 6X7. 705-749-0206.

International Customers: Please return product to your nearest distributor. If you do not know your distributor, please call 585-657-6161 and ask for our International Department for assistance.

IMPLIED WARRANTIES

ANY IMPLIED WARRANTIES INCLUDING THE IMPLIED WARRANTIES OF MERCHANTABILITY AND FITNESS FOR A PARTICULAR PURPOSE ARE LIMITED IN DURATION TO ONE YEAR FROM DATE OF RETAIL PURCHASE. SOME STATES DO NOT ALLOW LIMITATIONS ON HOW LONG AN IMPLIED WARRANTY LASTS SO THE ABOVE LIMITATIONS MAY NOT APPLY TO YOU.

To the extent any provision of this warranty is prohibited by federal, state or municipal law, which cannot be preempted, it shall not be applicable. This warranty gives you specific legal rights and you may also have other rights, which vary, from state to state.

CROSMAN and CROSBLOCK are registered trademarks of Crosman Corporation in the United States.

