



Made in
Britain

ERNEST H. HILL LTD • SHEFFIELD
www.hillpumps.com

USER INSTRUCTION MANUAL



EC3000 PORTABLE AIR COMPRESSOR

Contents

Parts Included	3
Set Up	4-5
Operating Instructions	5-8
Troubleshooting	9
Closedown	9
Storage	9
Maintenance	9



IMPORTANT

THIS PRODUCT IS DESIGNED TO **FILL** PRE-CHARGED PCP AIR GUNS AND PAINTBALL GUNS DIRECTLY. IT CAN ALSO BE USED TO **TOP UP** SMALL TANKS, BUDDY BOTTLES, AND CYLINDERS UP TO 4 LITRES. LARGE CYLINDERS AND TANKS ABOVE 4 LITRES SHOULD ONLY BE FILLED BY COMPETENT OR QUALIFIED PEOPLE

NOT FOLLOWING THE INSTRUCTIONS OR MISUSE OF THE COMPRESSOR WILL VOID YOUR WARRANTY AND MAY RESULT IN DEATH OR INJURY



DANGER

DANGER OF EXPLOSION

FROM OVERFILLING OF COMPRESSED AIR CYLINDERS



DO NOT EXCEED MAXIMUM FILL PRESSURE OF YOUR CYLINDER AT ROOM TEMPERATURE. ONLY FILL CYLINDERS THAT ARE IN GOOD CONDITION AND ARE IN DATE OF INSPECTION.



IMPORTANT

READ ALL INSTRUCTIONS BEFORE USE.
TO PROTECT YOUR EYES YOU SHOULD ALWAYS WEAR SAFETY GLASSES WHEN OPERATING THIS COMPRESSOR AND HEARING PROTECTION WHEN BLEEDING



WARNING

THIS COMPRESSOR PRODUCES CLEAN AIR SUITABLE FOR FILLING PCP AIRGUNS. IT DOES NOT COMPRESS AIR SUITABLE OR CERTIFIED FOR BREATHING APPARATUS. DO NOT USE IT TO FILL SCUBA TANKS THAT MAY LATER BE USED FOR BREATHING.

Parts Included

1x EC-3000 Compressor

1x Power Cable

1x High Pressure Filling Hose 1/8" and male Quick Release Coupling

1x Hill H8000 Oil

1x Hill Silicone Oil

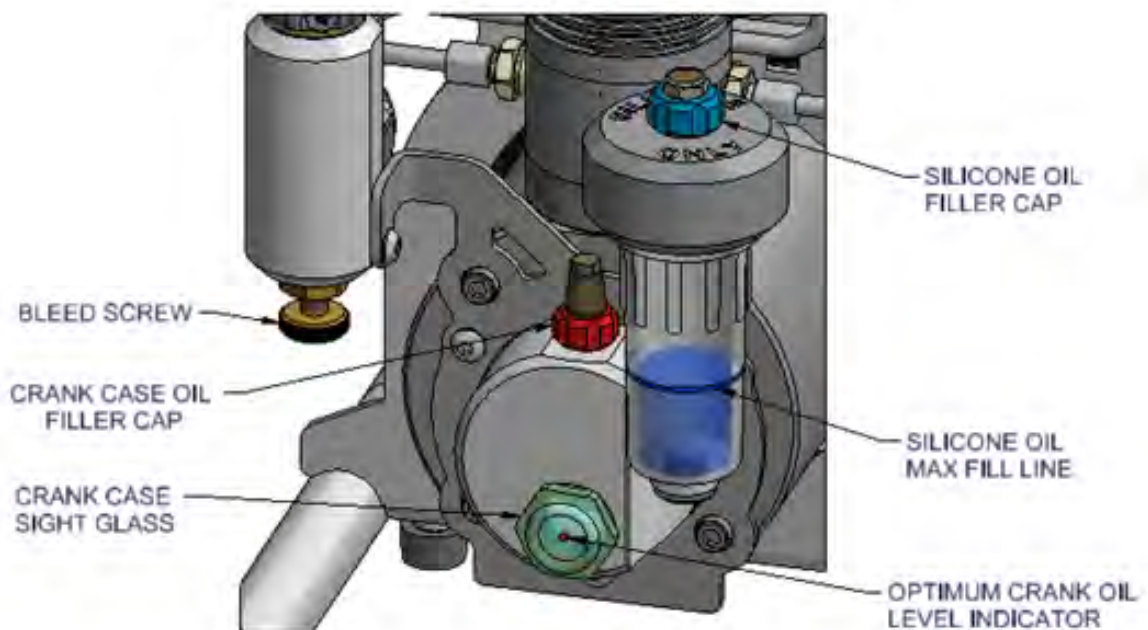
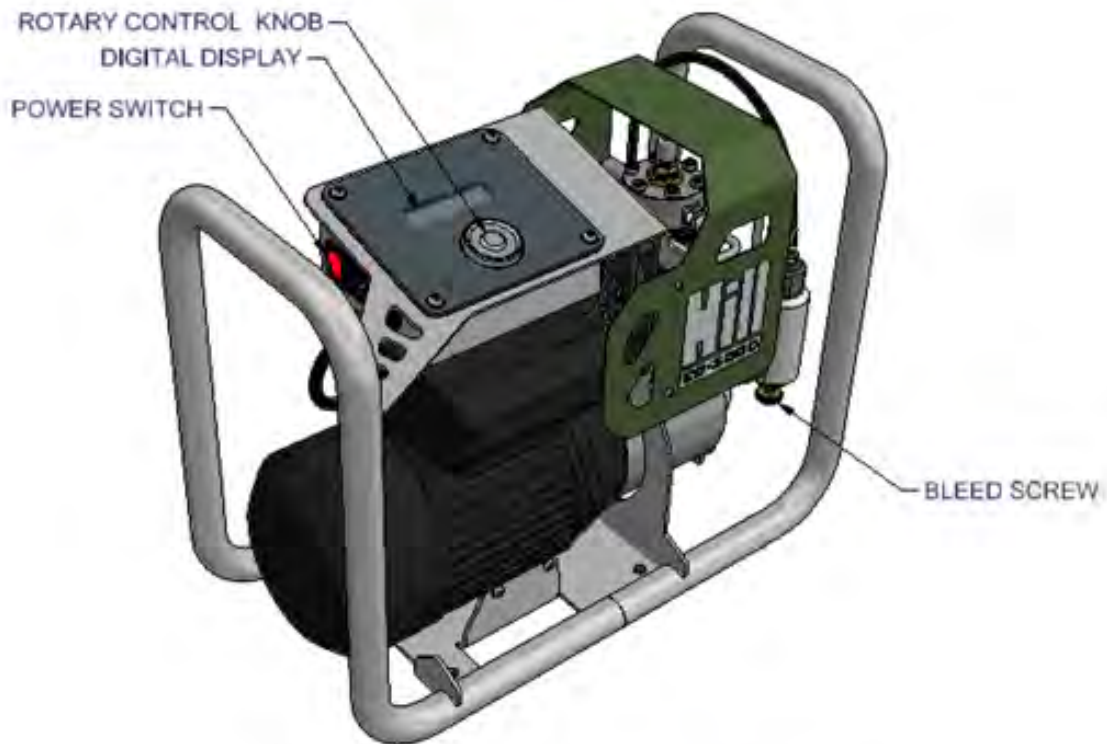

Set Up

CAUTION - please read and understand the following instructions before use.

CAUTION - ONCE YOU HAVE CORRECTLY FILLED THE COMPRESSOR WITH LUBRICANTS, THE COMPRESSOR MUST BE KEPT UPRIGHT AND LEVEL AT ALL TIMES. ENSURE THE COMPRESSOR IS USED ON A NON-SLIP FLOOR, PREFERABLE SAT ON ANTI-SLIP MATTING. IF THE COMPRESSOR IS TO BE MOVED OR TRANSPORTED FOR STORAGE OR MAINTENANCE, ENSURE ALL LUBRICANTS ARE DRAINED FIRST.

1. Oil Level

With the compressor positioned on a level surface, check that the oil level meets the red dot on the sight glass.

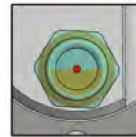

Top up as necessary using the following:

Remove rep cap - screw anti-clockwise



Slowly squeeze the Hill H8000 crank oil into the exposed hole until the lubricant level meets the red dot in the sight glass

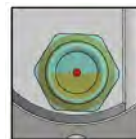

DO NOT MIX CRANK OIL AND SILICONE OIL AND DO NOT OVERFILL



Leave the oil to settle for 5 mins, if the oil level drops below the red dot apply more oil until the oil level is maintained

Replace the red cap until finger tight

2. Silicone Lubricant Level

Fill the lubricant reservoir up to the blue line using the following:

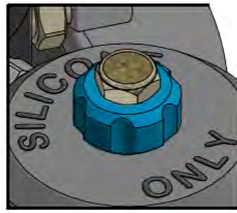

Remove blue cap - screw anticlockwise

Slowly squeeze the Hill Silicone Oil through the exposed hole until the oil reaches the limit indicated on the reservoir

DO NOT MIX CRANK OIL AND SILICONE OIL

Replace blue cap until finger tight

3. Power connection and Operating Instructions

Connect filling probe to hose, ensure spanner tight



Connect filling probe to cylinder, ensure spanner tight



Ensure bleed screw is closed (finger tight)



Insert power cable into pump



! **CAUTION:** If using a quick release coupling, always check and make sure the collar on the female quick disconnect is in the forward position and secure on the male fitting you are connecting it to. It is recommended that you check the connection by attempting to pull the female and male ends apart while the collar on the fitting is in the forward position.

Please avoid using any electrical extension leads if possible. However, if you are using a 3rd party extension lead, this must be rated to a minimum of 110v/16A or 230v/13A depending on your local power supply. If unsure, please determine what your local power supply is before operating the compressor.

Switch compressor on



The screen will briefly show the Hill logo, the software version and the accumulated running hours



before requesting confirmation that the lubricant levels have been checked and are correct



Press the rotary control knob to confirm the lube check



The display will then change to “set pressure”. A default pressure of 100BAR (1450PSI/10MPa) is displayed



If you are using the compressor for the first time, the unit of measure will display in BAR. To change the unit of measure to PSI or MPa, rotate the control knob clockwise and press to confirm



Rotate the knob again to alternate between BAR and PSI. When you have chosen the unit of measure, depress the control knob to confirm. The chosen unit of measure will be retained for future use even when the compressor is switched off. This can be changed at any time.

To return to the “set pressure” screen, rotate the knob anticlockwise and press to confirm

To set the pressure, rotate the control knob clockwise to increase the fill pressure required. When you reach the desired pressure, press the control knob to confirm.

The maximum pressure that can be set is 300BAR (4350PSI/30MPa). **DO NOT SET THE COMPRESSOR ABOVE THE MANUFACTURER'S RECOMMENDED PRESSURE FOR THE CYLINDER YOU ARE FILLING.** The target pressure is not retained for subsequent fills and will require resetting each time.



Rotate the control knob to reach the start display
Press the control knob and the compressor will commence filling
The display will show the operating temperature, the current working pressure and the target set pressure

You can manually pause the filling at any time by depressing the rotary control knob once, the display will show "Fill Abort?"
You can either confirm the fill abort by depressing the control knob once more or to resume the fill,



or rotate the control knob once more to show "Fill resume" and then press the knob to confirm

The compressor is programmed to only operate within a pre-set temperature range. The compressor will automatically pause if the working temperature exceeds this pre-set. **This is normal and no operator intervention is required.** The display will show the progress of the cooling cycle and when the working temperature falls below the pre-set the compressor will restart. If you are filling a larger capacity cylinder, this could happen multiple times. You can abort the fill at any time within the cooling cycle if required



When the target pressure is reached the display will show "Fill complete" along with confirmation of the working pressure and the target pressure.

DO NOT disconnect the cylinder until the compressor has been depressurised

Depressurise by releasing the bleed screw. Whilst depressurising, the compressor will expel some moisture and a small amount of lubricant. **Suitable precautions should be taken to protect any floor coverings under the compressor.**



The display will show the progress of the depressurisation until it reaches the minimum display value 0BAR. You can disconnect the cylinder.



The display will revert to the “set required pressure screen”

After one accumulative hour of pumping, the compressor will stop and request that you check the lubricant levels. The compressor will not restart until you press the control knob. If connected to a large diving cylinder, close the valve on the cylinder and take this opportunity to depressurise/drain the compressor.

DO NOT LEAVE THE COMPRESSOR UNATTENDED WHEN IN USE!

IN THE UNLIKELY EVENT THAT YOUR COMPRESSOR MALFUNCTIONS, DO NOT ATTEMPT TO FIX THE PROBLEM YOURSELF. PLEASE CALL THE DISTRIBUTOR YOU PURCHASED IT FROM.

PLEASE RETAIN THE ORIGINAL RECEIPT OF PURCHASE

The most up to date version of this instructions manual will be available at www.hillpumps.com
Please check this website regularly



WARNING



DANGER

DANGER OF ELECTRIC SHOCK

**DO NOT OPERATE OUTSIDE IN THE RAIN
DO NOT OPERATE WITH WET HANDS OR WET CLOTHES**



DANGER

PARTS OF THIS COMPRESSOR GET VERY HOT. DO NOT TOUCH THESE HOT PARTS



WARNING

**DO NOT TOUCH MOVING PARTS, FOR EXAMPLE THE COOLING FAN.
KEEP FINGERS AND LOOSE CLOTHING AWAY FROM MOVING PARTS**

Troubleshooting

- Compressor will not start

Make sure that the power cable is inserted correctly and that the compressor is switched on, check that the fuse in the switch has not blown

- Pressure does not exceed 50BAR and air escapes from the Pressure Relief Valve

See maintenance on website for Disc Valve cleaning

- Pressure asked for on compressor is not pressure in cylinder

Cylinder valve may cause small pressure loss, adjust pressure on compressor to compensate

Closedown

Make sure that the cylinder is removed and bleed screw is opened to release pressure

Storage

Keep upright at all times

Maintenance

Change both lubricants every 50 running hours or once yearly (whichever comes first)

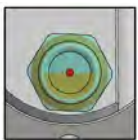

Unscrew sight glass to change Crank Oil (make sure you have a suitable container underneath) and drain.
Unscrew silicone oil bottle and change oil.

ERNEST H. HILL LIMITED

LONGACRE WAY - HOLBROOK - SHEFFIELD S20 3FS - ENGLAND

Telephone; +44 (0) 114 248 4882

www.hillpumps.com

sales@hillpumps.com