

FXairguns MADE IN SWEDEN



FX DREAMLINE OWNER'S MANUAL



THE DREAMLINE

With the arrival of the FX Dreamline, innovation that was previously only dreamed about, is now a reality. The FX Dreamline is the first fully modular airgun system in the world. The modular design allows the rifle to change to any of the Dreamline configurations. Today's hunting bullpup can be converted for the weekend field target match. The classic sporter rifle can be switched out to house all your favorite AR furniture and accessories. Whatever you can imagine is possible with the FX Dreamline.

The beauty of the FX Dreamline starts with the revolutionary world class FX Smooth Twist X barrel (STX). This is the same barrel housing and liner system as found on other elite rifles such as the FX Impact, FX Crown and FX Wildcat. The STX barrel allows the Dreamline the unique ability of changing both the caliber of the gun as well as the inner liner of the barrel to allow for different twist rates and other bore specifications. This provides a tailored barrel to meet the vast array of projectiles available today.

The Dreamline also includes the new AMP Regulator (Adjustable Match Precision Regulator). This robust regulator is revolutionary in that it can be adjusted externally either to higher or lower pressures without the need to remove pressure from the gun. The AMP regulator also uses the latest in high performance parts to provide precision accuracy that holds up over time.

The FX Dreamline features the same adjustability as found on other premium FX rifles. All adjustments can be fine tuned including valve flow, hammer tension, and regulator pressure. These adjustments are done quickly and easily allowing the shooter find harmonic balance and maximize the performance and accuracy of the Dreamline.

All FX Dreamline models utilize a large capacity rotary magazine. This is the same magazine used in the FX Crown and is indexed with the smooth cocking side lever. This newly designed side lever takes the ease of cocking a rifle to a whole new level as it is nearly effortless to cock.

Most Dreamline models offer a standard 220 cc cylinder filled up to 230 BAR, but there are also bottle versions of many of the configurations which will allow for more air and higher shot counts. 1/2" UNF threads on the barrel allow for the optional addition of a moderator. The FX Dreamline also features the world-famous FX match grade trigger, set at 15 ounces from the factory.

Warnings

- Never attempt to disassemble this rifle while it is charged!
- Never fire the rifle when it is empty of air or when air cylinder is removed!
- Never point the rifle at anyone, or allow anyone to point a rifle at you!
- Treat every rifle as if it is loaded even if you know it is not loaded!
- Always carry the rifle so that the direction of the muzzle is under control, even if you stumble.
- Always be sure of your target and what lies behind it before firing your rifle.
- Never leave a loaded rifle unattended.
- Beware of targets that tend to cause ricochets.
- It is recommended that eye protection is worn when charging the cylinder.
- Always use caution when operating this rifle.
- Learn and obey the laws in your location.
- Be responsible in your use of this rifle!
- Never fill the rifle with anything else other than regular air!
- Never fire the rifle below set regulator pressure.
- You are obliged to inspect carbon-fiber air tanks according to the instructions on the tank.

Failure to obey these instructions could result in personal injury or damage to the gun!

Warranty Information

All FX Airguns carry a ThreeYear Warranty against faulty workmanship and defective materials. If it becomes necessary, first contact the dealer from which you purchased the gun. If the rifle is determined to have a defect within the warranty period, contact the warranty center to arrange service. The warranty guarantee does not cover any damage caused by tampering with the rifle or abuse. This rifle should only be disassembled by factory-authorized repairmen.

Rifle Features

- Smooth-twist x barrel system (with changeable core barrel liner to obtain various twist rates).
- Note:** A separate manual is needed for this purpose.
- Interchangeable Caliber System.
 - Built-In Moderator (variations may occur depending on country).

- Easy to use fill probe system.
- External Power Adjuster (Hammerspring tension and airflow).
- Dual Manometers.
- Externally Adjustable Regulator.
- Adjustable Match Trigger (variations may occur).

Cleaning

- Keep the rifle clean and wipe it off with regular gun-oil and a cloth occasionally.
 - We recommend that you use cleaning pellets occasionally.
 - These you can use without the risk of damaging the barrel.
- WARNING: Never use chemicals or water to clean the rifle.

Storage

- Store dry and dark if possible.
- Preferable stored pressurized.

WARNING:

- *High humidity might cause corrosion if not treated correctly.*
- *Keep away from sunlight as this might damage o-rings and anodizing.*
- *Never store the rifle loaded with pellets*



Safety Operations

The safety is easy to use and is located on the right side of the action.

Note: Only use the safety when the rifle is cocked!

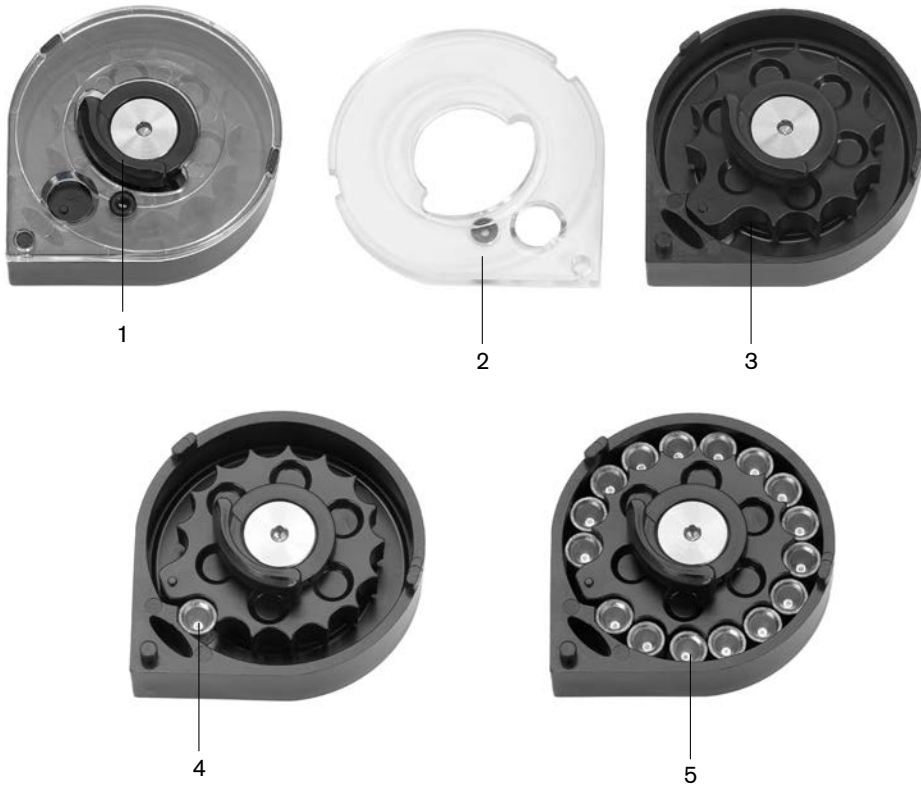

How to load the magazine

To load the Side-Shot magazine, start by rotating the center lid-lock (1) until you are able to remove the lid (2). Twist the inner pellet tray (3) counterclockwise until you hit the stop. Put a pellet into the first position (4) head first while holding your finger under the hole to stop it, release the pellet tray as the pellet you inserted will hold the magazine in place. Continue placing the rest of the pellets HEAD FIRST, make certain all the pellets fall in correctly into its slot (5). Once the magazine has been filled, put the lid back into position and twist the lid-lock until it is the opposite position of the cutout. Our guns are tested and tuned in the factory for best performance and accuracy with JSB pellets.

Charging the rifle

A quick connector is supplied with the rifle and is threaded with a 1/8" thread. Make sure that the thread is the same at the charging source before you attach it.



Fillprobe Type MkI:

Insert the fill probe into the rifle filler hole located at the end of the air tube.

Quick Connector MkII:

Push the connector over the male connector.

Close ventilation screw on the charging source. Charge the rifle to wanted pressure.

Always check the pressure on the charging source, they have in most cases a more reliable gauge. The gauge on the rifle is more of an indicator to see if you need to charge or not.

If a hand pump is used the moisture trap must be drained at regular intervals during the pumping cycle.

WARNING: Only dry air should be used! Under no circumstances should oxygen or any other gas be used to fill the airtubes! This could result in a serious injury or death.!

Cocking and Loading

With the rifle pressurized and magazine loaded, continue to prepare the rifle for use by pulling rearward on the cocking lever until it clicks in the rearward position.

Then set the safety to its safe position.

Carefully insert the magazine in the magazine slot, ensuring the pellets face the correct direction.

Press firmly to ensure the magazine is completely installed. Closing the cocking lever will now load a pellet into the barrel and make the rifle cocked and loaded. Switching the safety to "FIRE" will make the rifle ready to fire.

Be sure to keep the rifle pointed in a safe direction throughout this entire procedure.

Uncocking the rifle/inactivating trigger system

Pull the cocking lever to its rear position, put the safety to Fire.

While holding the cocking lever in its rear position you squeeze the trigger and at the same time you gently move the cocking lever forward. Trigger must be pulled throughout the whole procedure.





Adjusting the power

Setting the power on the Dreamline can be done with three external adjustments.

1. Front power adjuster (1) - The airflow adjuster is located on the left front side of the breechblock. This gives you the ability to adjust the power from high to low. Low setting is for low power on all caliber. Caliber Setting is max power for selected caliber. Variations in appearance might occur.

NOTICE – NEVER fire the airgun without air. Doing so may damage the valve assembly and will void your warranty!

2. Rear power adjuster (2)– The spring tension adjuster is located on the left rear side of the breech block.

The spring tension adjuster wheel is a quick way to fine tune the power and accuracy of your rifle and has 7 fixed levels.

Simply rotating the wheel while the gun is uncocked in either direction will set the power from Maximum to Minimum.

It will read letters on one side and figures on the other side as there can be small difference in power between the two sides. 1 and E is on the low side and 5 and A is on the high side.

NOTICE – NEVER adjust the power when rifle is cocked. Doing so might damage the power-adjuster wheel and will void your warranty!



3. Externally Adjustable Regulator

The adjustable AMP regulator is installed in the dreamline. It is located either on the bottle adapter (1) or installed within the Tube with an accessible hole pointing downwards (2).

To adjust the regulator pressure higher, turn the regulator AMP screw counter-clockwise slowly while looking at the regulator manometer located on the right hand side of the gun. To lower the regulator pressure, turn the regulator AMP screw clockwise a quarter turn at a time, dry firing the rifle until the correct pressure is achieved. Make sure your rifle is not loaded before dry firing.

NOTICE – Fire in a safe direction.

NOTICE – NEVER adjust the regulator above 160 BAR as damage to the system may occur and will void your warranty!

NOTICE – NEVER use the gun below the set regulator pressure as damage to the system may occur and will void your warranty!



Changing Caliber

When changing calibre on the system for the first time, be sure to follow these directions closely to avoid unwanted damage.

Make sure pelletprobe has the same caliber as the barrel before mounting. Make sure rifle is uncocked!

Barrel:

- Loosen screws on top of the breechblock (2).
- Pull the barrel out of the system.
- Insert new barrel and make sure the small slot in the barrel breech lines up with the guide pin inside the breech block.

- When completely seated, you should be able to see a small portion of the barrel assembly inside the magazine slot (3).
- Once in position, tighten the locking screws.
- Misalignment will cause poor performance and potential harm to the airgun.

NOTICE – Failure to tighten these locking screws can cause serious damage to the rifle if fired.

Pelletprobe:

- Start by pushing the sidelever to its rear position.
- Set the safety to its safe position.
- Then remove the pelletprobe locking screw (1).
- Pull the probe rearwards, replace and tighten the screw again.
- Uncock the rifle, see cocking and loading section.

NOTICE – Never fire the gun without pelletprobe mounted.

Notes for you own settings

Tip: Make note of the factory setting before you start tuning the rifle.

Caliber				
Regulator Pressure				
Main Power Setting				
Power tuning adjuster				
Energy				
Velocity				
Pellet Weight				
Pellet Type				
Distance				
Remarks				



Adjustments standard triggersystem:

For liability reasons, we cannot give detailed instructions on trigger adjustments.

The following diagram is a reference showing adjustment screws and what aspect of the trigger they adjust.

The 2nd Stage Adjustment (2) is the break or release weight adjuster.

The 1st Stage Length Adjustment (1) controls the travel or 1st Stage length.

NOTICE – Adjusting your trigger can easily make the rifle unsafe. Take caution in safely adjusting and testing your trigger with an **UNLOADED** magazine and empty barrel. Always point the rifle in a safe direction while adjusting the trigger. Never rely on the trigger or safety when pointing your rifle at any target. And, always test the rifle thoroughly following any adjustments to ensure safety and reliability.

NOTICE – All adjustments work in relationship with one another. Adjustments to one screw may affect the function of other aspects to the trigger. Proper function is a tuning of each adjustment, and should be performed by a trained specialist. Adjustments to the trigger are not a warrantied service.



Bullpup triggersystem:

First Stage, Length of pull (3)

Adjust screw 3 clockwise to reduce the length of first stage travel, but also affects point 4. 3 and 4 works together and might need some adjustment back and forth to get it right.

Second Stage. Resistance of pull (4)

Adjust screw 4 clockwise to increase resistance of the second stage, also affects point 3. 3 and 4 works together and might need some adjustment back and forth to get it right.

Trigger blade position (5)

Loosen screws and adjust rod to get wanted position of the trigger blade.

WARNING: Always make sure the safety works after adjustment has been made to the trigger system!



FXairguns

MADE IN SWEDEN

www.fxairguns.com