

Freedom8 ShoeBox Compressor Manual

Warning!! This product is not a toy! Use or misuse can cause severe injury or death! Use only with adult supervision. This unit is only to be used with tanks, hoses and fittings rated for a minimum of 4500 LBS per square inch. Do not operate with an input pressure of more than 125 pounds per square inch or less than 85 pounds per square inch to the compressor or explosion and injury will result. Unplug power before removing cover. Do not operate with cover removed. Under NO circumstances should this unit be used with CO2 tanks or any tank rated less than 4500 pounds per square inch.

⚠WARNING:
For your own safety, never operate unit until all assembly steps are complete and until you have read and understood the entire operator's manual.

⚠WARNING:
Do not put any type of oil into the compressor air lines or explosion could result.

Safety Instructions

This manual contains information that you should know and understand. Understanding this information is for your SAFETY and to PREVENT EQUIPMENT PROBLEMS. To help recognize this information, observe the following symbols.

Safety Signal Words

! DANGER indicates an imminently hazardous situation which, if not avoided, WILL result in death or serious injury.

! WARNING indicates a potentially hazardous situation, which if not avoided, COULD result in death or serious injury.

! CAUTION indicates a potentially hazardous situation, which if not avoided, **MAY** result in minor or moderate injury.

NOTICE indicates important information, which if not followed, may cause damage to equipment.

NOTICE:
! CAUTION:
! WARNING:
! DANGER:

!WARNING:
Only use white lithium grease for lubrication.

Intended Use

This compressor is designed to fill air tanks rated to 4500 or 3000psi depending on the model. For best performance it requires an 125 psi feed from a shop compressor (not supplied) to the nipple on top of the unit. We recommend one of the small shop compressors that are

!WARNING:
To reduce the risk of injury, if any parts are missing, do not attempt to operate the air compressor until the missing parts are obtained and installed correctly.

!WARNING:
Do not operate unit if damaged during shipping, handling or use. Damage may result in bursting and cause injury or property damage.

oil-free and generally cost less than 100 dollars. The compressor uses less than 1 cubic foot per minute and virtually all inexpensive shop compressors can deliver that flow rate.

Setup

The compressor as shipped does not have the fill nipple on top of the unit or the vent knob installed.



- 1: Find the fill nipple provided in the plastic bag and screw it into the threaded hole in the top of the compressor. There is Teflon sealing tape pre-installed on the fill nipple, do not remove. Use a wrench to fully tighten.
- 2: Remove the front cover after unplugging the power and all air lines by unscrewing the four bolts on the sides.
- 3: Take the vent knob shaft and screw it part way into the upper threaded hole just above the output nipple in the front.
- 4: Find the black retaining bolt with the wide head in the parts bag and screw that into the lower right threaded hole. You might have to screw the vent knob in and out to get the retaining screw into place and seated up against the block. Once properly in place, the vent knob shaft should be restrained by the retaining bolt, so it doesn't unscrew out of the block. Unscrew the vent rod all the way OUT to seal and pump up to pressure.
- 5: Reinstall front cover before use.

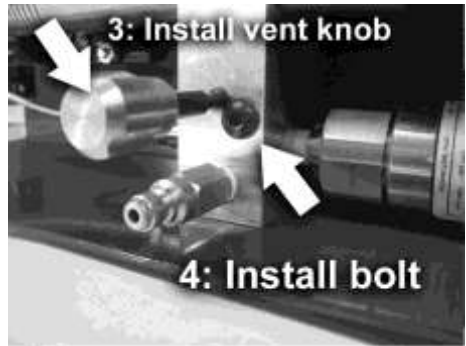

Shop Air Compressor for 125 psi Feed (not supplied)

To achieve minimum fill times, the F8 ShoeBox Compressor can handle up to 125 psi air from a small oil free air compressor. This acts like a “first stage” and reduces the fill times by a factor of eight. **Do NOT run the ShoeBox above 125 psi. Doing so will overload the first stage and reduce o-ring life.**

Air Feed Hookup

Before attaching input hose, set the output pressure of the shop compressor to 125 psi or less. Attach the hose from your shop compressor to the fill nipple you installed on top of the ShoeBox Compressor. Attach a high pressure rated hose to output port on the front of the compressor. Attach other end of hose to the fill nipple on your psi rated tank. Unscrew the vent knob above the output port on

the front until it hits the stop. Make sure all covers are secure and in place.

⚠WARNING:

Do not fill CO2 tanks under any circumstances or explosion, injury or death could result.

⚠WARNING:

This compressor is NOT DESIGNED TO SUPPLY BREATHABLE AIR.

Running Compressor

Plug in the compressor to an electrical outlet supplying 110 volts AC and push the black switch **all the way to the right** to start compressor. The switch arm will spring back to center and is only designed for momentary contact to the right to start the compressor. This is much like a car ignition switch. The switch arm is on a spring and will feel compliant to the touch. The compressor will start running. Monitor pressure build up on the tanks gauge. If no gauge is present on your tank, make sure to use a pressure gauge installed on the rated fill hose to monitor pressure. The compressor has an electronic shut off pressure switch set to 4500 psi. See adjustment section to adjust shut off pressure. Once compressor shuts off when the tank has reached the set pressure, remove the 125 psi compressor feed hose and screw in the vent knob until you feel resistance. From there, screw the vent knob about one additional turn just you hear the air venting from the airline vent hole. Once the air has COMPLETELY vented you may then disconnect your tank from the fill line. MAKE SURE to unscrew the vent knob back out or your compressor will leak when you turn it on next time.

⚠WARNING:

NEVER use any oil in any airline on this compressor or an explosion could result.

Lubrication

Follow the warnings in this manual and on the compressor and unplug all air lines and power from the unit before removing front cover. The four screws on the sides hold the cover in place.

Your compressor uses oil impregnated bushings which should not need

lubrication. **NEVER PUT OIL IN THE AIRLINES OF THE COMPRESSOR or an explosion could result!!**

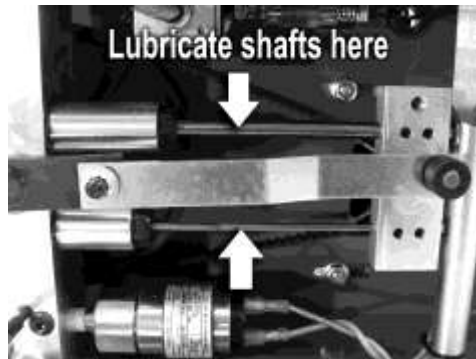

To lubricate both air pistons **ONLY USE WHITE LITHIUM GREASE**. Disassembly of the pistons is not required. Simply put a dab of grease on the exposed piston shaft near the end of the cylinder. Once the unit is turned on, the grease will get pulled into the cylinder as the piston moves in and out. See our website videos on the Support page at Shoeboxcompressor.com

AC Motor

The Dayton AC motor is 1/3 horsepower and runs off standard 110 volt household current. It should be plugged into a grounded 20 amp receptacle. The motor has built-in overload protection and will shut off

⚠WARNING:

If not properly grounded, this tool can cause an electrical shock, particularly when used in damp locations, in proximity of plumbing, or out of doors.

⚠WARNING:

The motor must be allowed to cool down before start-up is possible. The motor will automatically restart without warning if left plugged into electrical outlet, and the motor is turned on. Do not leave motor plugged in during cool down

if overheated. The motor will start unexpectedly when cooled off, so be sure to unplug unit if overheating occurs.

Belt Tension Adjustment

The F8 comes with a quiet cog belt drive. Loosen the motor bolt screws and slide the motor to tension the belt. The belt should be tight enough to 'twang'. More tension is better than not enough.

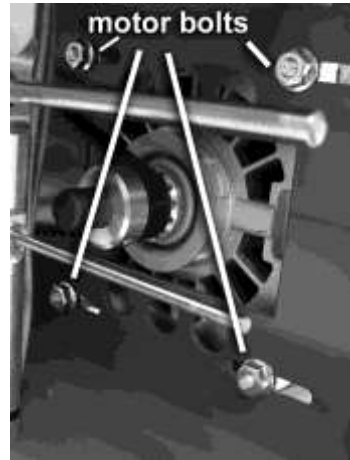

⚠WARNING:

Release all pressure and disconnect power before making any repair or adjustment.

Shut Off Pressure Adjustment

The electronic pressure switch in the F8 has an adjustable shut off between 300- 4500 psi. To adjust the shut off, slide the plastic collar back over the wires to expose the brass adjustment rod inside the switch. Use a small screw driver in the slots to turn the brass piece to adjust the shut off pressure. Return the plastic collar over the opening before starting.



Burst Disk Overload Protection

The ShoeBox Compressor is equipped with a burst disk that can be found behind the main air block. If the compressor sees pressures greater than approximately 7500psi, the copper seal in this device will blow out and vent the system. This burst disk is industry standard and must be replaced after a venting incident. Use the same pressure

rated burst disk for replacement. Replacements are available from our webstore: ShoeBoxCompressor.com under the 'Order' tab and then under 'Spare Parts'.

O-rings and Back Check Valves

There are only 7 o-rings which are active seals in the compressor. These o-rings are accessed by removing the cylinders. These o-rings should only be replaced after watching the rebuild videos on the website at Shoeboxcompressor.com. For technical support see go to our forum at: Shoeboxcompressor.com/forum/

⚠WARNING:
Burst disk must be replaced with unit pressure rated to the same specification as the one removed.

O-ring Air Line Fittings

A new feature on the F8 is our own custom o-ring fittings on the air lines. They are made to be user serviceable buy replacing the o-rings if they start to leak. There is a permanent ferrule clamped on the air line. Next comes a black steel washer that is removable so do not leave it off. Next is the white urethane o-ring which is the same one used for the lower piston. The nut no longer contributes to the sealing so do not over tighten.



Water Traps and Filters

There is no filter or water trap supplied with this compressor. We recommend filtering the incoming 125 psi line. See your shop compressor dealer for these accessories. There are additional links to useful water traps and other accessories on the website at Shoeboxcompressor.com

⚠WARNING:

For your own safety do not try and run the air compressor while troubleshooting.

⚠WARNING:

Do not spray flammable materials in vicinity of open flame or near ignition sources including the compressor unit.



Heat Buildup

Under normal running conditions the parts inside the compressor can reach temperatures in excess of 150 degrees Fahrenheit. Handling these parts immediately after shutdown can cause severe burns. Never spray the compressor with any flammable material or solvents. Always use the compressor in an area with adequate ventilation.

Warranty

There is a 90 day parts and labor warranty to the original purchaser from date of purchase. The customer is required to send the unit back to us at their expense, we will repair or replace the defective parts and ship the unit back. Technical Support is handled online at Shoeboxcompressor.com under the ShoeBox Compressor forum. Most questions are answered the same day.

The warranty applies only to the original purchaser at retail and may not be transferred.

TECHNICOR INDUSTRIES MAKES NO WARRANTIES, REPRESENTATIONS OR PROMISES AS TO THE QUALITY OR PERFORMANCE OF ITS AIR COMPRESSORS OTHER THAN THOSE SPECIFICALLY STATED. TECHNICOR INDUSTRIES, INC. MAKES NO WARRANTIES OR REPRESENTATIONS, EXPRESS OR IMPLIED, INCLUDING AS NOTED BELOW.

ADDITIONAL LIMITATIONS

To the extent permitted by applicable law, all implied warranties, including warranties of MERCHANTABILITY or FITNESS FOR A PARTICULAR PURPOSE, are disclaimed. Any implied warranties, including warranties of merchantability or fitness for a particular purpose, that cannot be disclaimed under state law are limited to three years from the date of purchase. Technicor Industries is not responsible for direct, indirect, incidental, special or consequential damages. Some states do not allow limitations on how long an implied warranty lasts and/or do not allow the exclusion or limitation of incidental or consequential damages, so the above limitations may not apply to you. This warranty gives you specific legal rights, and you may also have other rights, which vary from state to state.